

Provided for non-commercial research and education use.  
Not for reproduction, distribution or commercial use.



This article appeared in a journal published by Elsevier. The attached copy is furnished to the author for internal non-commercial research and education use, including for instruction at the authors institution and sharing with colleagues.

Other uses, including reproduction and distribution, or selling or licensing copies, or posting to personal, institutional or third party websites are prohibited.

In most cases authors are permitted to post their version of the article (e.g. in Word or Tex form) to their personal website or institutional repository. Authors requiring further information regarding Elsevier's archiving and manuscript policies are encouraged to visit:

<http://www.elsevier.com/authorsrights>

Contents lists available at [SciVerse ScienceDirect](#)

# Computers and Electronics in Agriculture

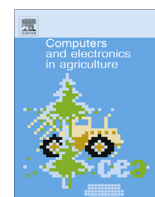
journal homepage: [www.elsevier.com/locate/compag](http://www.elsevier.com/locate/compag)

## A framework for wireless sensor networks management for precision viticulture and agriculture based on IEEE 1451 standard



Miguel A. Fernandes<sup>a,e</sup>, Samuel G. Matos<sup>b,e</sup>, Emanuel Peres<sup>f,e</sup>, Carlos R. Cunha<sup>c,a</sup>, Juan A. López<sup>d</sup>, P.J.S.G. Ferreira<sup>b</sup>, M.J.C.S. Reis<sup>b,e</sup>, Raul Morais<sup>f,e,\*</sup>

<sup>a</sup> CITAB – Centre for the Research and Technology of Agro-Environment and Biological Sciences, Quinta de Prados, 5001-801 Vila Real, Portugal

<sup>b</sup> JEETA – Signal Processing Laboratory, Dept. Electrónica, Telecomunicações e Informática, Universidade de Aveiro, 3810-193 Aveiro, Portugal

<sup>c</sup> IPB – Instituto Politécnico de Bragança, Campus de Santa Apolónia, 5301-854 Bragança, Portugal

<sup>d</sup> DSIE – División de Sistemas e Ingeniería Electrónica, Technical University of Cartagena, Campus Muralla del Mar s/n, Cartagena E-30202, Spain

<sup>e</sup> UTAD – Universidade de Trás-os-Montes e Alto Douro, Quinta de Prados, 5001-801 Vila Real, Portugal

<sup>f</sup> INESC TEC (formerly INESC Porto) and UTAD, University os Trás-os-Montes e Alto Douro, Vila Real, Portugal

### ARTICLE INFO

#### Article history:

Received 24 September 2012

Received in revised form 21 March 2013

Accepted 1 April 2013

#### Keywords:

IEEE 1451

Precision agriculture

Precision viticulture

Wireless sensor networks

Gateway

IEEE 802.15.4

### ABSTRACT

Precision viticulture (PV) and precision agriculture (PA) requires the acquisition and processing of a vast collection of data coming typically from large scale and heterogeneous sensor networks. Unfortunately, sensor integration is far from being simple due to the number of incompatible network specifications and platforms. The adoption of a common, standard communication interface would allow the engineer to abstract the relation between the sensor and the network. This would reduce the development efforts and emerge as an important step towards the adoption of “plug-and-play” technology in PA/PV sensor networks. This paper explores this need and introduces a framework for smart data acquisition in PA/PV that relies on the IEEE 1451 family of standards, which addresses the transducer-to-network interoperability issues. The framework includes a ZigBee end device (sMPWiNodeZ), as an IEEE 1451 WTIM (Wireless Transducer Interface Module), and an IEEE 1451 NCAP (Network Capable Application Processor) that acts as gateway to an information service provider and WSN (Wireless Sensor Network) coordinator. The paper discusses the proposed IEEE 1451 system architecture and its benefits in PA/PV and closes with results/lessons learned from in-field trials towards smarter WSN.

© 2013 Elsevier B.V. All rights reserved.

### 1. Introduction

PA and PV practices depend on the acquisition, transmission and processing of a vast collection of data coming from a large scale, heterogeneous sensor network (Camilli et al., 2007). These characteristics and the obvious need for wireless data transmission immediately raises two issues. The first is energy-related. The challenge is how to obtain sufficient energy and how to manage it, so that all electronic devices can enjoy virtually uninterrupted operation. Previous work (Morais et al., 2008a,b) gave valuable information on how to support devices that communicate with each other in an IEEE 802.15.4/ZigBee mesh network with energy harvesting techniques to power data acquisition devices with multiple sensors.

The second issue has to do with the normalization and interoperability related to the multiplicity of sensors, sensor output types, multi-vendor data acquisition platforms and network support. In

PA/PV practices there are many sensors with different types of output: voltage, current, wired digital (RS-485, SDI-12) and many other types. This diversity affects the way sensors are integrated in a data acquisition network.

The multiplicity of incompatible network specifications and distinctive data acquisition platforms make the integration of heterogeneous sensors far from simple (Tani and Cugnasca, 2005). The adoption of a common and standard communication interface to abstract the sensor/network/user relation would cut down development efforts, reduce installation and configuration complexity, and facilitate the “plug-and-play” of sensors to a network (Oostdyk et al., 2006; Hu et al., 2007; Lee, 2008), improving interoperability and reducing the implementation, deployment and maintenance costs.

Solutions to meet these challenges would contribute decisively to improve precision viticulture practices. The need for a framework for interoperability to accommodate these systems and support heterogeneous sensor applications using consensus-based standards to connect sensor networks has been noted before (Song and Lee, 2007). Chen and Helal (2008, 2009) had reviewed and analyzed the standards developed to normalize the process of acquir-

\* Corresponding author at: UTAD – Universidade de Trás-os-Montes e Alto Douro, Quinta de Prados, 5001-801 Vila Real, Portugal.

E-mail address: [rmorais@utad.pt](mailto:rmorais@utad.pt) (R. Morais).

ing and handling data from transducers (Echonet, SensorML, DeviceKit, Device Description Language, IEEE Transducer ML and IEEE 1451), and concluded that the IEEE1451 family of standards arises as the most comprehensive. Besides ensuring the appropriate standardization of data and procedures for data acquisition, it also normalizes the process of communications between devices which, in itself, may represent a huge benefit provided that the implementation of these standards is adequately structured with the necessary services support.

Our perspective is that the combination in a framework of standards such as IEEE 1451 and IEEE 802.15.4/ZigBee will effectively simplify the integration of devices and equipment in a distributed PA/PV environment, which is characterized by heterogeneous data acquisition systems. This will free farmers from the technical issues often met in such systems (Song and Lee, 2007).

In line with this perspective, the present paper describes the architecture and implementation of a comprehensive framework that transforms data acquisition platforms and makes possible the “plug-and-play” connection of various sensors. In our opinion, the need for and usefulness of such a framework has been felt for long, but its implementation has been left behind mainly due to the complexity of the IEEE 1451 family of standards.

This article is organized as follows: After introducing the problem of interoperability in Section 1, Section 2 presents a brief overview of IEEE 1451 and what benefits can be extracted from the simplification of configuration and use procedures of wireless sensor networks in PA/PV practices. Section 4 presents the hardware and software that have been used and how the MPWiNodeZ platform described in Morais et al. (2008a) has been upgraded to become fully IEEE 1451 compliant. Regarding the WSN sink node, the functional architecture of an in-field gateway, where all services necessary for the implementation of a complete IEEE 1451 system have been incorporated, is also described. Section 5 describes the IEEE 1451 implementation and the sequence of operations needed to interact with a data acquisition platform. In addition, we present a brief description of the IEEE 1451 management tool, developed in Java language, which accesses the in-field gateway and allows to configuring the devices and collect all data from a proof-of-concept WSN. It ends with lessons learned from this research and valuable information on how to implement a complex but comprehensive standard that can be effectively used to create smarter PA/PV technologies.

## 2. Overview of IEEE 1451 standard

Important efforts have been concentrated on the definition, functionality and communication standards for smart sensors. The goal is interoperability for a wide range of applications. The smart sensor, with appropriate local decision-making capability, can act as an intelligent node in a network, with interoperability aimed as the key argument for an obvious need to support various data acquisition platforms across different networks for network independent operation. Such effort would help expedite the development of networked smart transducers. Towards this goal, the IEEE and the National Institute for Standards and Technology (NIST) have pioneered the development of a set of standards known as IEEE 1451.

The IEEE 1451, a family of Smart Transducer Interface Standards, describes a set of open, common, network-independent communication interfaces for connecting transducers (sensors or actuators) to microprocessors, instrumentation systems, and control/field networks. The key feature of these standards is the definition of Transducer Electronic Data Sheet (TEDS), fully described in IEEE Std 1451.0-2007, which stores transducer identification, calibration, correction data, measurement range, manufacture-re-

lated information, and other information, which can be remotely retrieved through a common set of interfaces enabling a “plug-and-play” procedure for transducer handling. The characteristics of self-configuration and self-description provided by TEDS help to minimize human errors and by manually entering of data for configuration reduce the need for technical expertise for setting up and maintaining a monitoring system (Oostdyk et al., 2006).

A simplified functional structure of a IEEE 1451-based system is depicted in Fig. 1. IEEE 1451 divides a sensor network system into two general categories of devices, the Network Capable Application Processor (NCAP) and Transducer Interface Module (TIM). NCAP is a processor-based device that acts as a gateway between two levels of a sensor network with two different interfaces.

To the lower level, the NCAP exchanges data with a set of TIM devices where transducers are attached through Transducer Channels (TC). To this effect, NCAP incorporates a communications support to ensure connectivity with the TIM according to the communications technologies adopted by the IEEE 1451 family. To the higher level, the NCAP represents the interface of a distributed monitoring system to a higher level of a network where IEEE Std 1451.1-1999 specifies a simple, complete object model for building smart sensor and actuator-based systems. Remote access to WSN data is thus facilitated by a set of standard services and functionalities that form a layer of middleware services for network management applications.

Support communications between NCAP and TIM is normalized and described separately by a subset of IEEE 1451, regardless of the subset IEEE 1451.0, where several possibilities exist: point-to-point (IEEE 1451.2), approved wireless radios (IEEE 1451.5), and RFID systems (IEEE 1451.7). The subset IEEE 1451.5 introduces the Wireless Transducer Interface Module (WTIM), a particular case of TIM where communication is based on an approved wireless radio (IEEE 802.11, IEEE 802.15.4/6LoWPAN, Bluetooth or IEEE 802.15.4/ZigBee). In any case all the specifications for effective communications are contained in the structures of Physical TEDS (format, fragmentation and packaging methods for the messages used in communications technology).

Each TIM includes the TEDS associated with each transducer which completely defines it. Furthermore, the NCAP may request the TIM's TEDS, in order to interpret correctly each sensor reading, or send TEDS to be stored in each TIM by using any approved com-

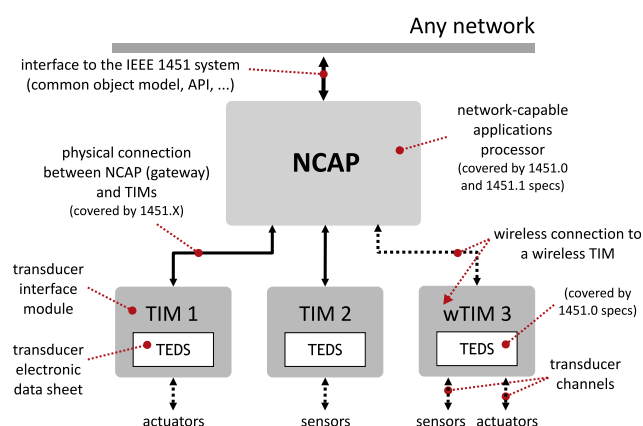

**Fig. 1.** Under IEEE 1451, a sensor/actuator system is divided into two parts: a Transducer Interface Module (TIM) containing the sensing or actuating element and including signal-conditioning circuits, and a Transducer Electronic Data Sheet (TEDS), digital data that identifies the type of sensor, its calibration information, scale factor, and more. Each TIM is connected to a network-capable applications processor (NCAP), which provides an interface to any network, by a subset of the IEEE 1451 standard.

munications medium. More information on all TEDS can be found in IEEE Std 1451.0-2007.

### 3. IEEE 1451 in PA/PV environments

PA/PV applications often depend on spatial and temporal variability studies and employ variable rate technology (VRT) to manage crop inputs. Not surprisingly, they show one of the highest rates of adoption of information technology and communications technology in agriculture.

In these studies and/or techniques, an enormous amount of data is collected in real-time by sensors that measure a wide variety of parameters related to crop growth. The wide diversity and heterogeneity of available sensors for this purpose places serious difficulties both for end users and manufacturers. The end users have to struggle with the configuration of the recording equipment, and manufacturers need to worry about making their sensors compatible with the majority of the data collection equipment. The adoption of the IEEE 1451 in PA/PV applications aims to simplify these procedures across all distributed and heterogeneous environments.

Since the publication of the IEEE 1451 family of standards, several studies have been carried out (Wei et al., 2005; Oostdyk et al., 2006; Nemeth-Johannes et al., 2007; Song and Lee, 2008; Wobsc-hall et al., 2009; Higuera and Polo, 2010; Seng et al., 2011; Barrero et al., in press). Higuera et al. (2009) described an IEEE 1451 implementation of a WSN based on IEEE WSN 802.15.4/ZigBee where WTIMs were implemented using Tmote Sky modules (Moteiv Corporation, USA). NCAP was implemented over the same Tmote Sky module with a USB connection to a computer. The application interface to the sensor network was developed in LabVIEW and it allows the sending of commands to the WTIM and data storage in a database. This work contributes to the enhancement of IEEE Std 1451.5 ZigBee PHY TEDS by adding eleven new registers for ZigBee support. However, it does not take into account PA/PV specificities and only works on transactions initiated by the NCAP, an option that makes impossible sending out data from the WTIM to the NCAP at periodic intervals without the need for pooling the WTIM.

Tani and Cugnasca (2005) in turns analyzed the application of IEEE 1451 in PA and how it could help to improve the processes of adoption of WSN and how the various players could benefit from the introduction of standards with interoperability characteristics, and exchange data independently of the communications network. They point out that the various services provided by the IEEE 1451 network element allow for the implementation of two aspects considered essential: the integration of sensors and data acquisition platforms on the same network communications standard and availability of data in SI units.

Specifically for PA, Wei et al. (2005) describe a weed sensing system based on IEEE 1451 and ISO 11783, a communication protocol used in many agricultural machines and based on the SAE J1939 protocol (which includes CANbus). The NCAP is connected to other devices using the ISO 11783 bus, which enables connection to non-IEEE 1451-systems. However, only part of the software module that handles the NCAP interface was based on the IEEE 1451.1. It also described the hardware and software of the implemented TIM (IEEE Std 1451.2-1997) and its TEDS. It concludes that IEEE 1451 provides a flexible solution for the integration of embedded systems from different manufacturers. The modular design and “plug-and-play” capability are attractive and so IEEE 1451 may be a major help to speed up further development of PA technologies.

In the context of IEEE 1451 and its integration into PA/PV environments, we associate the data acquisition network with WTIM devices and their TC, which correspond to the deployed transduc-

ers (sensors and/or actuators). On the other hands, network coordination is left to a NCAP as a part of an in-field gateway, which manages the WTIM devices and performs basic data integration and aggregation. The adoption of the IEEE 1451 viewpoint brings several advantages:

- Uniform device description – every device has a corresponding description in the TEDS. As a result, it is always possible to obtain information about any transducer: physical variable, response time and operating modes, among others.
- Easier installation and maintenance – incorporation of additional devices is greatly simplified, in a step towards “plug-and-play” capability. The TEDS incorporated in the WTIM supply all the required information in a transparent way to the acquisition system. Replacing or upgrading sensors (for example, to improve accuracy) becomes a simple matter.
- Heterogeneity support – IEEE 1451 was conceived with diversity in mind, and in concept it is well suited to the PA/PV scenario, in which the monitoring of a variety of physical variables is the rule.
- Data integration and aggregation – the values of the physical variables acquired in the field (temperature, solar irradiance, relative humidity, etc.) can be transmitted in SI units. This distributes the overall required processing and greatly simplifies the processing, integration and aggregation of data.
- Diagnostic – The state registers associated with the TIM and their TC allow detecting and report any malfunctions to subsequently carry out any correction.

To the best of our knowledge, there is no implementation of this standard in the universe of PA/PV as comprehensive as the one reported in the next sections. For example, we are not aware of any other work in which a WTIM can start a data transaction over an IEEE 802.15.4/ZigBee network by its own initiative, i.e., without the need for polling by the NCAP.

## 4. Materials and methods

The scenario chosen to incorporate the set of IEEE 1451 standards in a PA/PV environment, and serve as a testbed for developing and testing intelligent data acquisition devices, comprises a set of data acquisition units with all hardware resources needed to implement all IEEE 1451 services over a WSN based on the IEEE 802.15.4/ZigBee, and an in-field sink node responsible to manage all the data gathering process. Since each analog sensor is not compliant with IEEE 1451, the sMPWiNodeZ data acquisition platform was upgraded to become an IEEE 1451.5 WTIM, where the attached sensors have their TEDS/TC stored in the WTIM memory. In the following sections, the functional architecture of the network used in this research and the most relevant aspects of the implementation are described.

### 4.1. Architecture overview

The solution that we propose to address several frequently occurring problems in WSN for PA/PV applications relies on the sMPWiNodeZ platform and iPAGAT gateway (Peres et al., 2011). A number of sMPWiNodeZ nodes are deployed throughout the area of interest, to monitor and acquire data from a number of possible heterogeneous data sources. The incorporation of IEEE 1451 services in the sensor network yields a new view of it in terms of NCAP and WTIM entities. On one hand, the iPAGAT gateway becomes (or incorporates) the IEEE 1451 NCAP, allowing external data access using IEEE 1451 services through the iPAGAT data integration system. On the other hand, the data acquisition platforms

become WTIM entities that operate under IEEE 802.15.4/ZigBee. Fig. 2 illustrates the functional architecture of a WSN operating under IEEE 802.15.4/ZigBee and IEEE 1451.5, from the point of view of the application considered in this work: monitoring a large number of heterogeneous data sources in PA/PV.

A set of WTIM is deployed in the field, operating under a network configuration determined by IEEE 802.15.4/ZigBee. The information about the associated sensors is described in TEDS, eliminating the need to configure the remote system for the correct interpretation of the stored data. The iPAGAT thus becomes one of the central components of this distributed data acquisition system. Firstly, it coordinates all the WTIM to which it is connected over IEEE 802.15.4/ZigBee, allowing data collection by category. Secondly, it offers an internal set of services that allow data storage in a local database, which can be accessed subsequently by means of external queries. Finally, the network becomes fully scalable since an arbitrary number of iPAGATs is allowed. This brings to our distributed architecture a normalization of the configuration and insertion procedures of the platforms and sensors in the network, greatly simplifying tasks such as sensor upgrading, and therefore cutting down system and maintenance efforts.

4.2. Functional description of the in-field gateway and network nodes

The software structure of the iPAGAT gateway was deeply changed to accommodate all necessary IEEE 1451 NCAP services to create a smart, distributed monitoring network. Fig. 3 overviews the inclusion of IEEE 1451 family of standards over an existent IEEE 802.15.4/ZigBee WSN accordingly to Fig. 2.

As can be seen in this architecture, the NCAP is seen essentially as a gateway between the external network and the remaining elements of the IEEE 1451 system, the WTIM (Wiczer and Lee, 2005). From the point of view of the external network, the WSN manager uses the NCAP IEEE 1451.1 API to access and manage WSN data to fill the iPAGAT local database. To accomplish these goals, the iPAGAT implements the following NCAP services:

- IEEE 802.15.4/ZigBee physical interface – Hardware device that supports IEEE 802.15.4/ZigBee and, being part of iPAGAT, operates as a ZigBee coordinator for creating and managing the

WSN. It must also implement the services to add and remove devices from the ZigBee network, manage the communication paths, ensure data exchange, among other;

- IEEE 1451.5 services – Software layer that implements IEEE 1451.5 subset responsible for all processing and exchange of messages between NCAP and WTIM when communications are performed on IEEE 802.15.4/ZigBee;
- IEEE 1451.0 services – Software layer that deals with all IEEE 1451.0 services. The NCAP must be able to interpret all information received from each WTIM and sending commands and TEDS for the WTIM and associated TC. It is also required that the NCAP can identify all sensors attached to each WTIM, interpret essential information about sensing units, measurement limits, acquisition times, modes of operation, and other related information;
- IEEE 1451.1 services – This layer is an example of an external network interface, allowing remote access to information contained in the NCAP. There are other alternatives including the HTTP protocol described in IEEE 1451.0 subset and a set of Smart Transducer Web Services proposed by Song and Lee (2007).

In the architecture represented in Fig. 2, three management levels are shown. At the WSN level, a set of sMPWiNodeZ devices incorporate the necessary IEEE 1451 services to become a WTIM on IEEE 802.15.4/ZigBee communication technology. Despite being a mesh-type network, i.e., some devices operate as routers, the connection between each WTIM and its NCAP is a logical star which illustrates the abstraction layer that covers all IEEE 802.15.4/ZigBee network devices. Each sMPWiNodeZ unit can operate as a ZigBee router in which case, as it is only required to transmit network packets, does not require IEEE 1451 services since there is no need to interpret the data. The iPAGAT represents the second level, the entity responsible for in-field collecting and processing data before making them available to the management level, which can coordinate and centralize data from one or more iPAGATs in a distributed architecture.

As can be inferred from the observation of Fig. 3, iPAGAT gateway had seen its software structure grow with the inclusion of IEEE 1451 services that builds the NCAP. Its core is now built around a

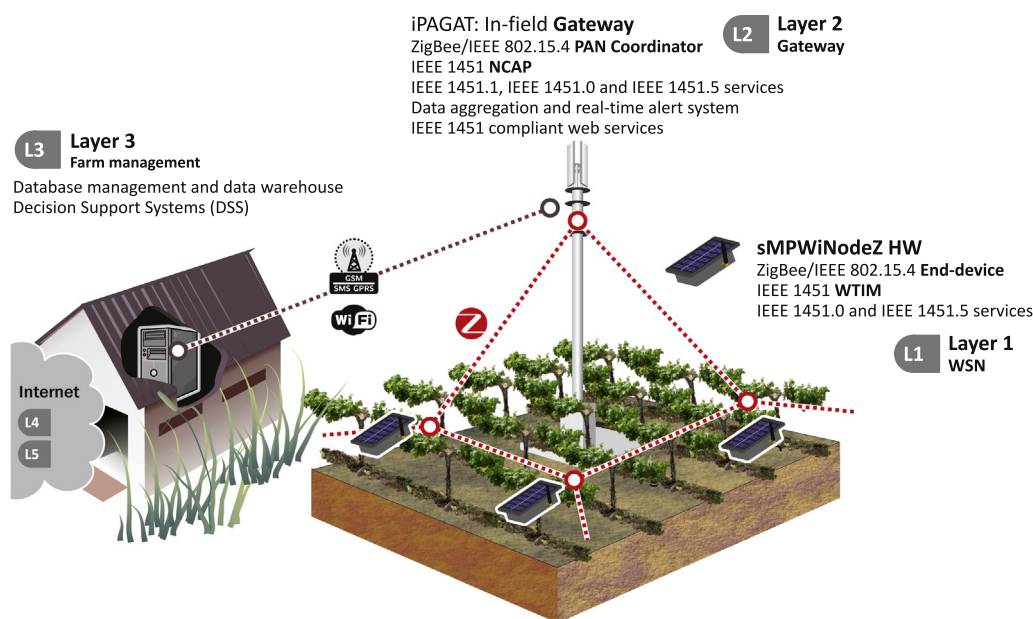
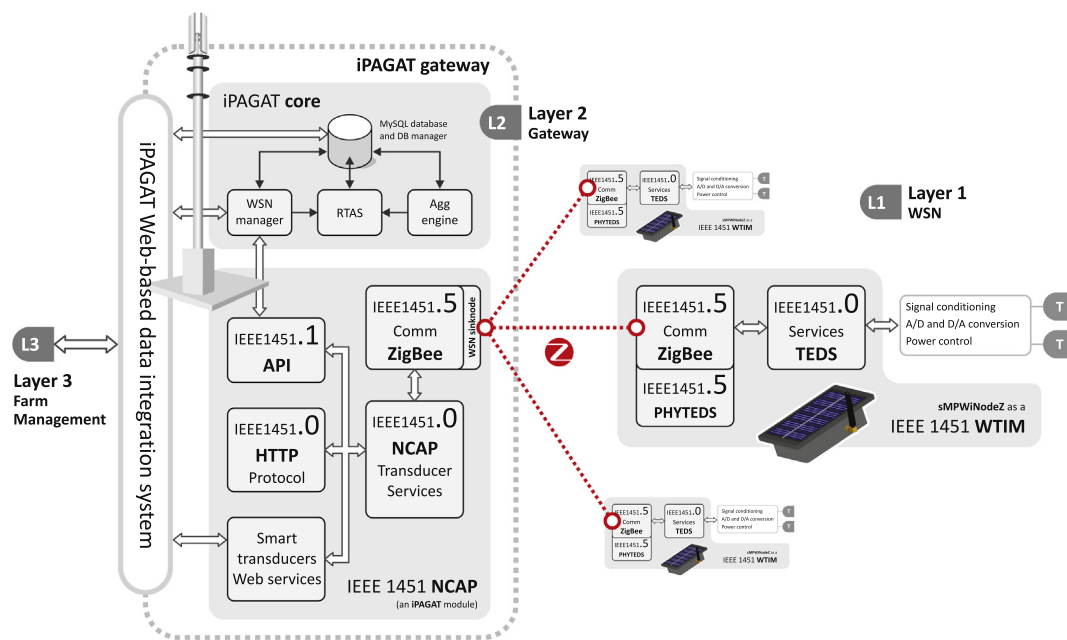

Fig. 2. Illustration of an IEEE 1451 WSN compliant network deployed over a vineyard, emphasizing IEEE 1451 concepts and entities. Each WSN node is a WTIM device while the NCAP acts as a sink node (gateway) to collected data.



**Fig. 3.** Functional architecture of the iPAGAT gateway acting as a IEEE 1451 NCAP and related WTIM data acquisition platforms, based on sMPWiNodeZ. iPAGAT core uses IEEE 1451 NCAP services to access WSN data and store it into a local MySQL database using a WSN manager.

data aggregation engine, a real-time alert system (RTAS) and a WSN manager that makes MySQL data inserts into a local database. Access to iPAGAT, and consequently to the NCAP, is accomplished through its data integration system that grant access to data stored in local database and enables remote gateway configuration.

4.3. The sMPWiNodeZ platform and WTIM services

The sMPWiNodeZ platform, illustrated in Fig. 4, is an upgrade version of the MPWiNodeZ (Morais et al., 2008a) and implements all functions to turn it into a WTIM IEEE 802.15.4/ZigBee.

It has a 32-bit RISC microcontroller with IEEE 802.15.4/ZigBee support (JN5148, Jennic, UK) with 128 KB RAM, 128 KB ROM and 4 MB flash memory. In order to meet the energy needs for perpetual operation (when operating as a router) the sMPWiNodeZ platform can use three independent power sources: solar, wind and moving water in irrigation pipes, as described in Morais et al. (2008b), allowing its internal LiPo battery to charge even when the system is in sleep mode. These energy transducers were also specified as IEEE 1451 transducers, where their TC were characterized within the WTIM structure. The protection against excessive discharge of the battery is also carried out by hardware. The system power is provided by a high efficiency DC-DC converter

(MAX1673, Maxim Integrated Products, USA) and a second converter is used exclusively for sensors power supply, being activated only when needed for readings. Analog inputs are provided allowing the connection of sensors with voltage output, an input for sensors with frequency output and a digital input for sensors with embedded digital protocol (SPI, I2C). A separate EEPROM (25LC020A, Microchip, USA) has been included for storing all WTIM TEDS. A real-time clock (DS1343, Maxim Integrated Products, USA) provides all timing signals needed for scheduling tasks and time stamps associated with sensor readings.

The sMPWiNodeZ platform is ruled by a set of software structures responsible for energy, communications and peripherals management, with special emphasis on reducing energy consumption. Fig. 5 illustrates the structure of software services with emphasis on IEEE 1451 and its relations with the main application. The interface block called *Sensors and actuators HW interface* is responsible for physical interaction with the transducers, such as their powering, signal conditioning and analog-to-digital conversion.

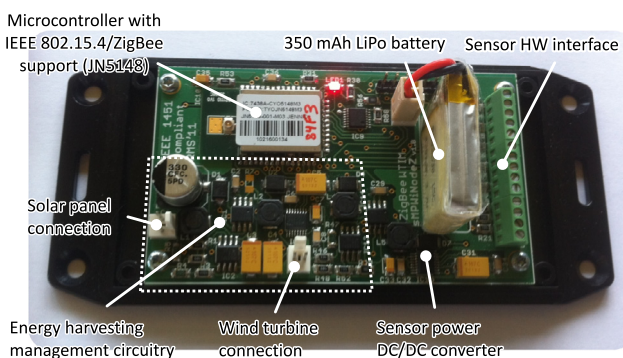

**Fig. 4.** Picture of the sMPWiNodeZ platform, an IEEE 1451 WTIM.

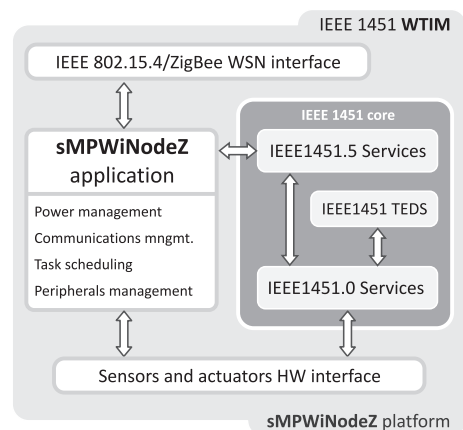

**Fig. 5.** sMPWiNodeZ platform software structure, which ensures its operation in accordance with IEEE 1451.0 and IEEE 1451.5 IEEE 802.15.4/ZigBee.

The sMPWiNodeZ platform implements all IEEE 1451.0 services (defines TEDS structure, command and response messages formats and state registers) and IEEE 1451.5 services (responsible for data exchange between a WTIM and NCAP on IEEE 802.15.4/ZigBee networks). Two types of messages are defined: *set* and *setRsp*. The first one is used to send all kinds of data between devices, i.e., TEDS, sensor readings, the register readings, and others, while *setRsp* messages are used to confirm delivery of data packets and to identify potential errors during the communication process. During data reception several operations are performed (unpacking, error checking and messages defragmentation) before it can be handled by the IEEE 1451.0 layer. When a WTIM sends a message, this layer is responsible for the generation of the appropriate response, i.e., receive data from the lower layer (IEEE 1451.0) and execute the processes needed for it to be sent to the NCAP in the correct format, ensuring their delivery to the recipient.

Fig. 6 illustrates the simplified state machine of the sMPWiNodeZ application, illustrating the relationship between IEEE 1451 states, IEEE 802.15.4/ZigBee management and power management.

After hardware initialization, it is necessary to search for an IEEE 802.15.4/ZigBee network and connect to its coordinator. Afterwards, all IEEE 1451 layers can be initiated in the state *WTIM-initialization*. During this state, the IEEE 1451.0 and IEEE 1451.5 services are configured and all existing TC are checked and added to the data structure of the IEEE 1451.0 layer. This process involves the initialization of the state registers, attributes, as well as reading and verification of the TEDS for all WTIM's and their TC. In its normal operation, the WTIM periodically comes out from *WTIMSleep* state, checks the available energy and if passed it goes to the *WTIMActive* state during which the sMPWiNodeZ can receive command messages from the NCAP. The TC associated with each sensor uses a free running sampling mode and the data transmission mode has been set to streaming at fixed intervals. This configuration enables the autonomous sending of readings to the NCAP at regular intervals, without the need for any NCAP polling. If requests from the NCAP are pending, these are processed as soon as the WTIM enters its active state.

#### 4.4. The iPAGAT gateway and NCAP services

We consider the iPAGAT to be the key element of the proposed architecture in Fig. 2, since it performs a set of in-field operations and manages simultaneously a set of devices for heterogeneous data gathering. As such, in addition to all the services needed to create a distributed IEEE 1451 system, the iPAGAT implements a

set of additional services available to level 3, referred to, in this work, as the farm management level.

The iPAGAT can be remotely accessed through the services provided by its embedded data integration system for gateway management, WSN monitoring and configuration. In addition, it provides access to IEEE 1451 NCAP services, such as WTIM discovery, TEDS management, transducer access, transducer management and WSN collected data. The data integration system also enables data queries to the NCAP data as well as iPAGAT aggregated data. It is also possible to monitor each WSN node including traffic, link quality indicator, and available energy using NCAP services.

The NCAP was implemented in Java programming language and has been structured into three main components: Network Communication (NC), Transducer Services Interface (TSI) and Module Communication Interface (MCI). The functional architecture is shown in Fig. 7.

The NC component provides a set of services used for communication between any network/external applications and the NCAP. This access can be accomplished by one of three methods (IEEE 1451.1 API, IEEE 1451.0 HTTP Protocol or Smart Transducers Web Services). The method described in IEEE 1451.1 subset defines an object model with a network-neutral interface for connecting processors to communication networks, sensors, and actuators. The TSI component contains the services and methods defined in the IEEE 1451.0 allowing full interoperability at data level. In the application, the class *TranducerServicesInterface* implements the services *TranducerAccess*, *WTIMDiscovery*, *TEDSManager*, *TranducerManager* and *CommManager* allowing a full interaction with WTIM, TC and TEDS.

The component MCI implements all IEEE 1451.5 services being constituted by the classes: *ModuleCommunicationsInterface*, *NetTwoWayClient*, *NetOneWaySubscriber* and *NetOneWayPublisher*. The *ModuleCommunicationsInterface* class implements the interfaces *NetComm*, *NetRegistration*, *NetReceive* and holds a current list of NCAP's registered WTIM and their properties. *NetTwoWayClient* class is used for bidirectional communications initiated by NCAP, while *NetOneWaySubscriber* and *NetOneWayPublisher* classes are used in one-way communication between WTIM and NCAP and vice-versa. At a lower level, *ZigBeeCommModule* and *RS232* classes performs the interface with the IEEE802.15.4/ZigBee WSN coordinator. The *ZigBeeCommModule* class checks for the arrival of new messages and their validity. It is also responsible for managing the WSN coordinator and processing incoming messages, while managing pending ones. The use of *ZigBeeCommModule* class allows greater independence

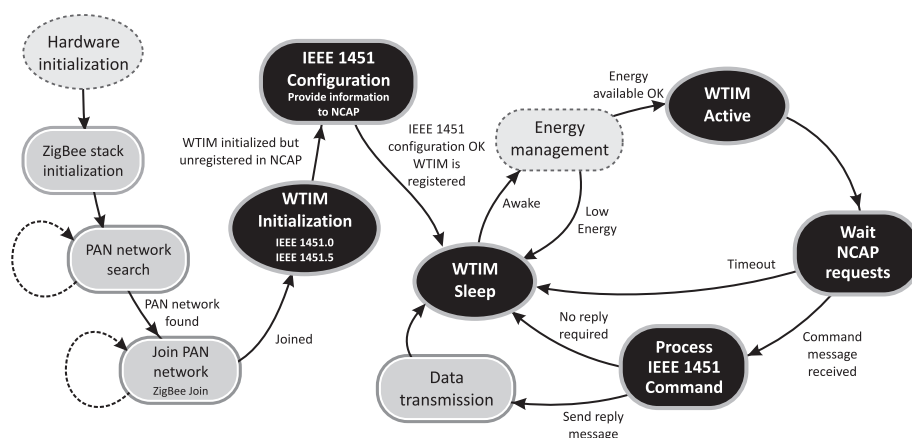

Fig. 6. Simplified representation of the state machine implemented in the sMPWiNodeZ platform. The states *WTIM Initialization*, *WTIM Sleep* and *WTIMActive* are defined by IEEE 1451 and are part of the operation of the WTIM.

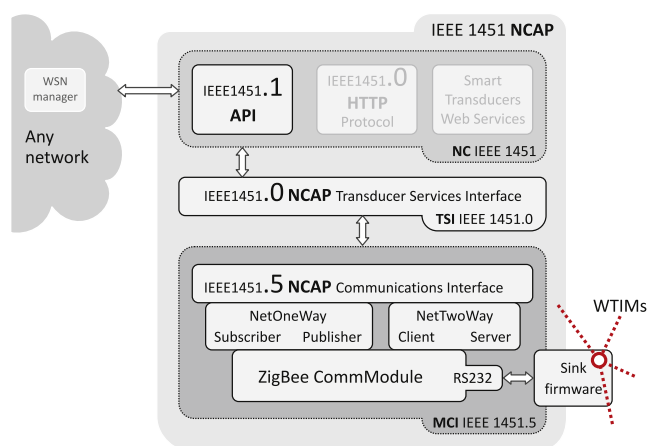

Fig. 7. Functional software architecture of the Java NCAP application embedded in the iPAGAT gateway.

between the MCI component and radio technology adopted. The RS232 class consists of two separate processes responsible for receiving and sending messages to and from the WSN coordinator through an RS232 serial interface. In Section 5, these events are illustrated.

Fig. 8 illustrates a simplified view of the state machine regarding the implementation of all IEEE 1451 services in the iPAGAT.

When it starts, the NCAP obtains its initial settings stored in the iPAGAT database (MCI type, max number of TIMs, MCI and TSI name descriptions, etc.). IEEE 1451.1 and IEEE 1451.0 services are then initiated as well as the IEEE 1451.5 communications module. After initiation of the network coordinator and registering of the NCAP communications module, the ZigBee PAN network is ready to accept new network elements. After the registration of the communications module, it becomes active and waits for new WTIM announcements. In this case, the NCAP is notified of a registration request by the ZigBee stack which is responsible for assigning an address to the new WTIM. When processing the registration request, the NCAP query the iPAGAT database to validate the WTIM and proceeds to the WTIM registration by requesting all TEDS in the WTIM to identify all the channels and associated units.

Whenever the WTIM announcement event is generated by a reconnection, NCAP checks whether the WTIM had any TC in the operate state proceeding to its activation automatically. The services provided by the IEEE 1451.1 API allows sending commands

and TEDS for the WTIM and the reception of TEDS from the WTIM. In order to ensure faultless operation, the NCAP and the sink node are monitored by a service module (NCAP maintenance) at regular time intervals.

The simplified data model for supporting the entire structure of IEEE 1451 data is divided by functional group: data tables and WSN management tables (subdivided into monitoring and configuration).

The data collected by the WSN are stored in a table called `sensordata`. This table encapsulates the values, in SI units, the associated geographical and temporal context and a field used to index the measurement units. This table feeds the iPAGAT data aggregation engine comprising a local 7-day long WSN data warehouse available through the data integration system. A table called `aggdata` stores the last sensor reading, time stamps, the maximum and minimum daily values, their occurrence times, and the average daily value. More details can be found in Peres et al. (2011).

The tables that belong to the management group allow the WSN manager to monitor and configure the network, providing the Management Information Base (MIB) for the entire integrated management platform. The `monitoring` table contains a snapshot of the network status at a given time (topology, packets sent and received, the battery voltage levels of each WTIM and the time stamp of the last connection). It allows the history of the network and its elements to be traced in time. An `incidents` table stores possible occurrences detected by the network manager (e.g. loss of connectivity of a WTIM). Monitoring group tables store dynamic information about the WSN manager.

The configuration group comprises the `ipagat`, `ncap`, `tims` and `channels` tables. The configuration parameters of the iPAGAT, NCAP, deployed TIMs and their TC are stored here. The NCAP table includes all IEEE 1451 device properties, including the ZigBee coordinator configuration and MCI and TSI software modules. The TIM and TC tables characterize each data acquisition platform and its channels, including TEDS, IEEE 802.15.4/ZigBee network address, the geographical coordinates of each deployed TIM and the types of the sensors used per channel.

### 5. Experiments and results

In this section we describe and discuss some of the experiments and results obtained with the system described, emphasizing the role of the mesh-type ZigBee WSN and its in-field gateway, in the light of the IEEE 1451 framework. The experimental setup has been deployed in the campus of the Universidade de Trás-os-

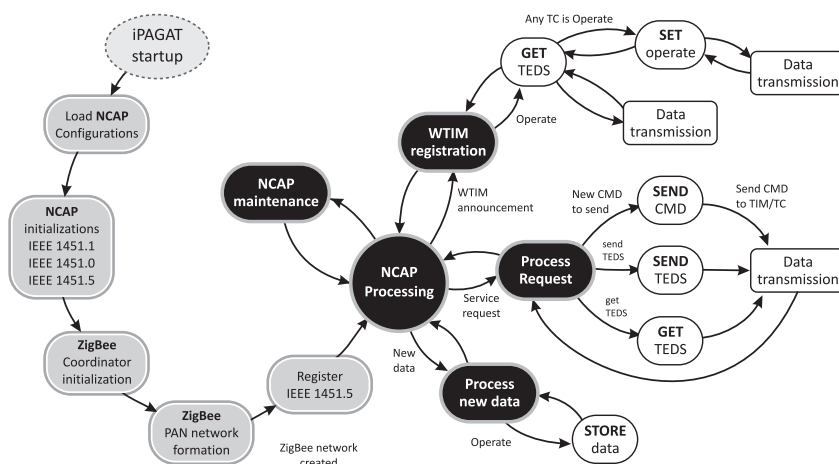
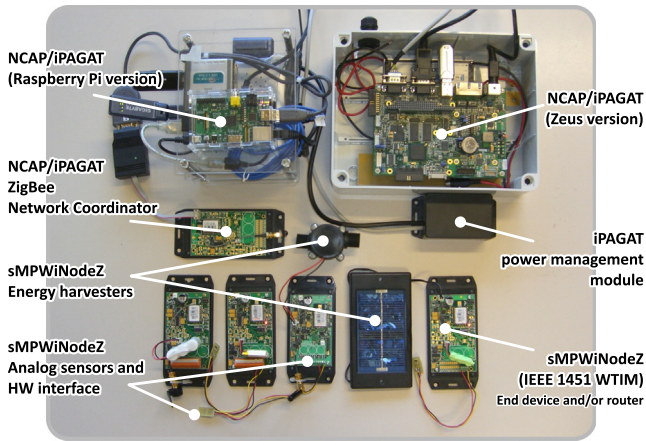

Fig. 8. A simplified state machine representation of the NCAP implementation.





**Fig. 9.** Devices used in the testing and demonstration WSN. A set of sMPWiNodeZ platforms were configured as IEEE 1451 WTIM. The implementation of the NCAP, as part of a gateway, was initially based on a SBC Zeus and in later stages on a Raspberry Pi (both are shown in the picture).

Montes e Alto Douro, Vila Real, Portugal, since May 2009. In reference to the present paper, it consists of six nodes, one of which is the NCAP (iPAGAT). The remaining nodes are WTIMs (sMPWiNodeZ). At the ZigBee network level, four devices operate as end-devices and one device as a router. Fig. 9 illustrates all devices in the WSN.

The WTIMs were fitted with four TC sensors and four embedded TC actuators to configure the period of time between data acquisitions. The TC includes a temperature sensor LM50B, the battery voltage, the solar irradiance obtained through the solar panel and a channel used to transmit management data (battery voltage, Link Quality Indicator (LQI), bytes sent/received, parent and status bits) to the NCAP. In order for the sMPWiNodeZ platform to operate as a WTIM, we configured it with the appropriate *MetaTEDS*, *Xdcr*-

Name and *PHYTEDS*. For each of the TC, the corresponding *ChanTEDS* and *XdcrName* were also configured, with the help of the *TEDSManager* application (Matos et al., 2012).

The management of the iPAGAT gateway or gateways (there can be one or several) and its components is performed remotely at the farm management layer (L3 in Fig. 2) using the Java application *iPAGATRemoteManager*, which accesses the services provided by the gateway layer (*WSNservices*) and enables a set of management and data collection tasks (real-time monitoring, configuration, status and historical events). Tasks such as IEEE 1451 NCAP configuration, management zones or even selected variables used by the data aggregation engine (form *frmIPAGATConfig*) are performed within this application. Fig. 10 illustrates the general appearance of the application.

The main window uses the *frmTree* form to display all elements of the integrated management platform. The data exchanged between the application and the selected iPAGAT is shown below that (*frmCommunications*). The WSN incidents are shown at the bottom (*frmIncidents*). The device tree, displayed in more detail in Fig. 10, allows an intuitive interaction with the iPAGAT, with the NCAP, WTIM and their TC as well as the several TEDS configured in WTIM and TC clearly visible.

The monitoring of the WSN nodes uses a map as its central structuring element. The map provides a simple and intuitive interface to the WSN elements (iPAGAT and their WTIM). The logical connections between elements, summary information and status of each component (address, coordinates, etc.) are all represented and geo-referenced. It is also possible to observe traffic data between iPAGAT and each WTIM and display the battery voltage of each one as well as its LQI. The monitoring can be performed over a specified time period, but real-time monitoring is also possible. It is also possible to generate CSV (Comma Separated Values) reports to a file. All of these WTIM dynamic data monitoring options are available using the interface shown in Fig. 11.

The interface *frmTIMConfig* shown in Fig. 12, allows full WTIM/TC configuration. In addition, some useful information is

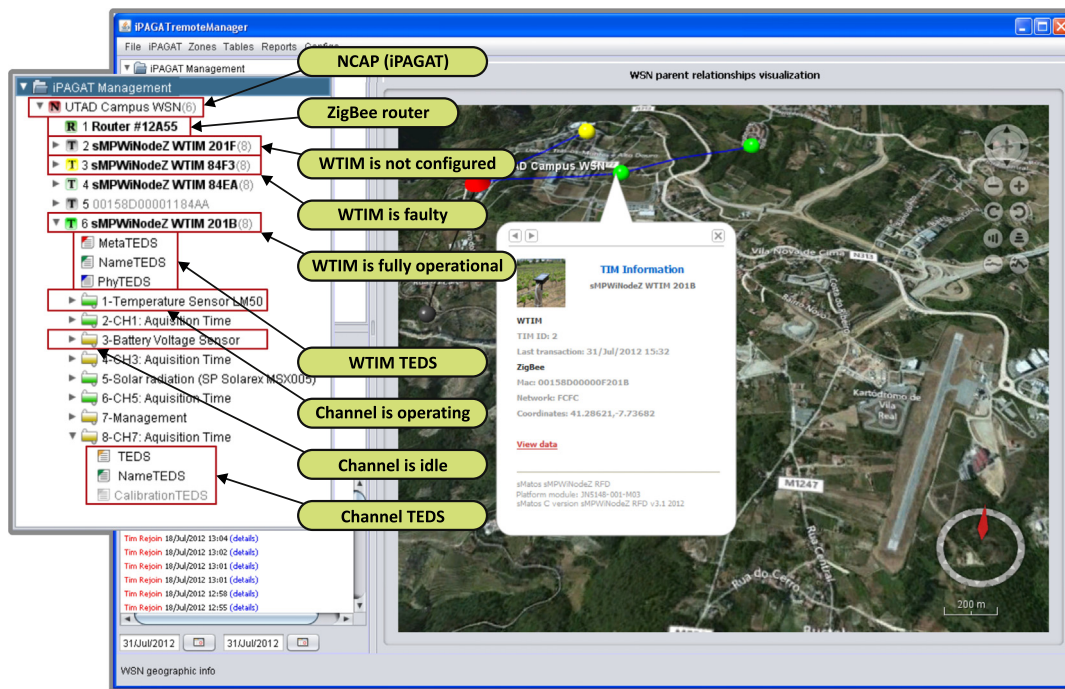

**Fig. 10.** The Java application that allows the remote management of the iPAGAT gateway and its components. Emphasis on the iPAGAT management tree, illustrating all WTIM details, regarding status, activity and installed TEDS. It makes the complete integration and management of an IEEE 1451 NCAP, as part of the iPAGAT gateway, possible and convenient.

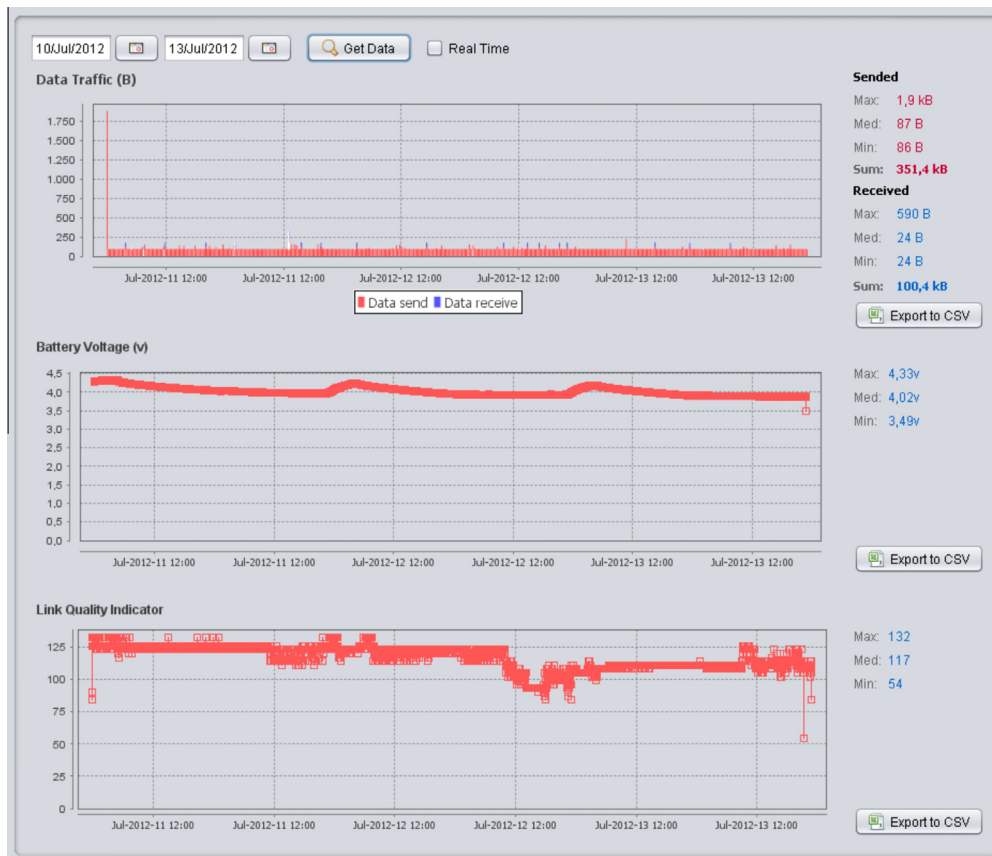

Fig. 11. Real time data visualization interface for each WTIM. Traffic bytes, WTIM battery voltage levels as well as LQI are displayed. Data can also be exported to other office tools.

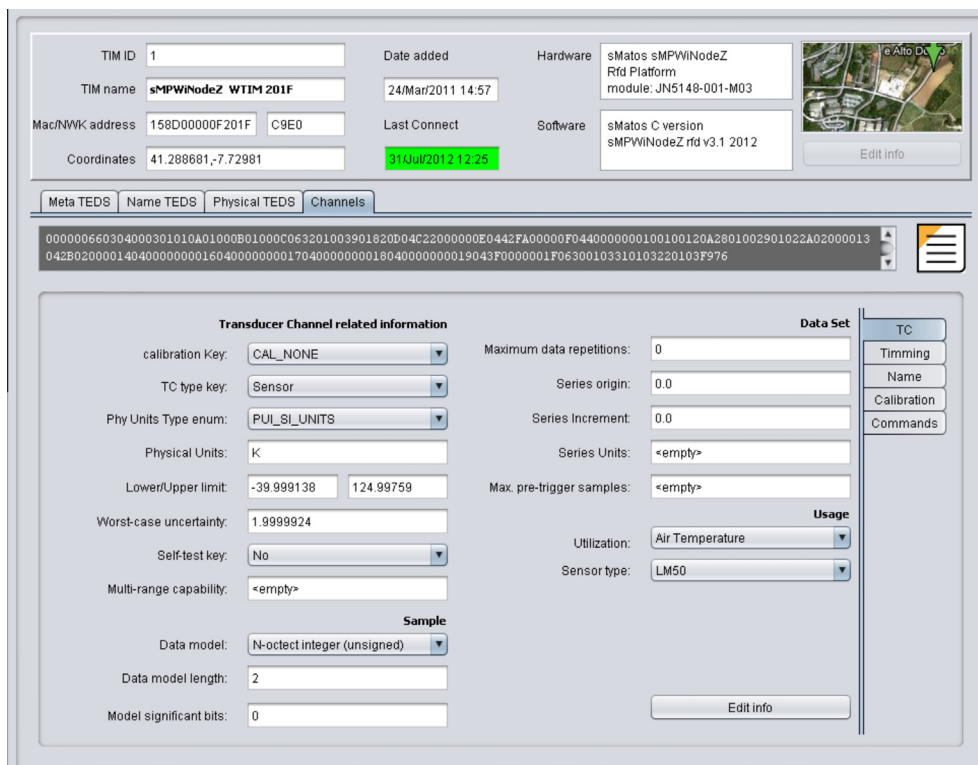
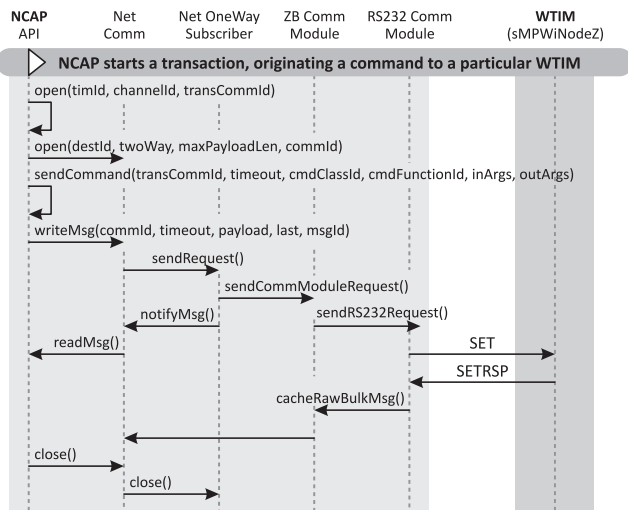

Fig. 12. Java interface used to configure all WTIM parameters.



**Fig. 13.** Operations sequence for sending a command from NCAP to a WTIM accordingly to IEEE 1451.0 specification. This sequence is used, for instance, to program the TC of a WTIM to operate on every sampling period.

presented such as WTIM network address, location and date of the last connection, and TEDS/TC of selected WTIM. It is also possible to display all mandatory IEEE 1451.0 (MetaTEDS, XdcrName, ChanTEDS) and IEEE 1451.5 (PHYTEDS) TEDS. There is an additional feature that we have found useful: it is possible to send TEDS for a specific WTIM and/or TC; activate (*operate* state) or deactivate (*idle* state) a specific channel, or even change the TC acquisition time period.

In the case of sensors that may be added by the user to a sMPWiNodeZ platform, their TEDS and TC may be remotely configured using the *iPAGATRemoteManager* and downloaded to the WTIM through the network or be programmed through the *TEDSManager* tool.

Two distinct transactions types between the NCAP and a WTIM may occur. The transmission of a command to each WTIM for configuration or actuation purposes is one type. The other type is the periodic transmission of acquired data by each WTIM, an important capability because it avoids the need for the NCAP to poll each WTIM in the network (as described by Higuera et al. (2009)).

Fig. 13 illustrates in a precise way the timing of the sequence of operations needed to send a command from the NCAP to a WTIM following the IEEE 1451.0 specification. Examples of such remote configuration commands are WTIM configuration, calibration, enabling/disabling TC and setting acquisition period. For instance, in order to instruct a sensor to perform periodic readings, one simply needs to activate its TC by sending an *operate* command to the WTIM. Besides the associated TC/sensor, an embedded pair of virtual TC/actuator was created as an IEEE 1451.0 control group. This procedure enables the setting of the sampling acquisition period using the same procedure, i.e., by sending a command to the embedded virtual actuator where the parameter is the desired time period. This is an important improvement because it normalizes all WSN related procedures, an important step towards interoperability.

Once configured, the TC proceeds to trigger sensor readings at periodic time intervals and sends each sample value to the NCAP without any need for polling. The diagram in Fig. 14 illustrates the process of receiving a new sensor data from the WTIM. Once received, decoded and processed by the several NCAP modules, data are stored in the *iPAGAT* database through the module *WSNmanager*.

The command/response pairs and message formats are described in Fig. 15 as an example when a temperature sensor con-

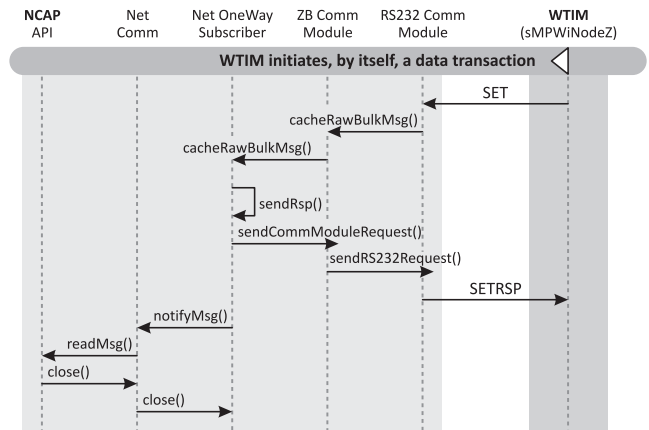

**Fig. 14.** Operations sequence for receiving incoming data from a sensor attached to WTIM operating in the free running mode. For instance, this sequence is used to retrieve data from a WTIM that is transmitting temperature readings every 5 min.

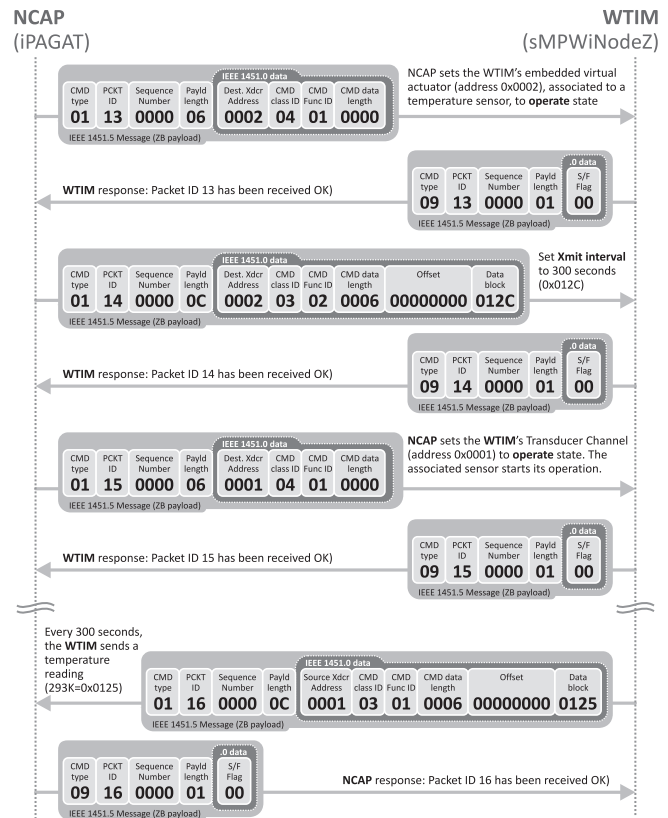

**Fig. 15.** Command/response pairs and message formats used to describe WTIM's TC configuration operations. The last pair illustrates the transmission of a sensor reading to the NCAP without the need of NCAP polling.

nected to a WTIM sends data with a sampling interval set to 300 s. The first three pairs describe WTIM configuration operations and the last one illustrates the transmission of the sensor reading to the NCAP. If the sensor is associated with channel 1 (TC) of the WTIM, then, to start collecting data, the corresponding TC must be activated, that is, placed in the *operate* state. To change the state of the TC, a sequence of events must take place. Among other functions, this allows switching on and off the sensor, define the period of time between readings, and, in the case of an actuator, to change its output status.

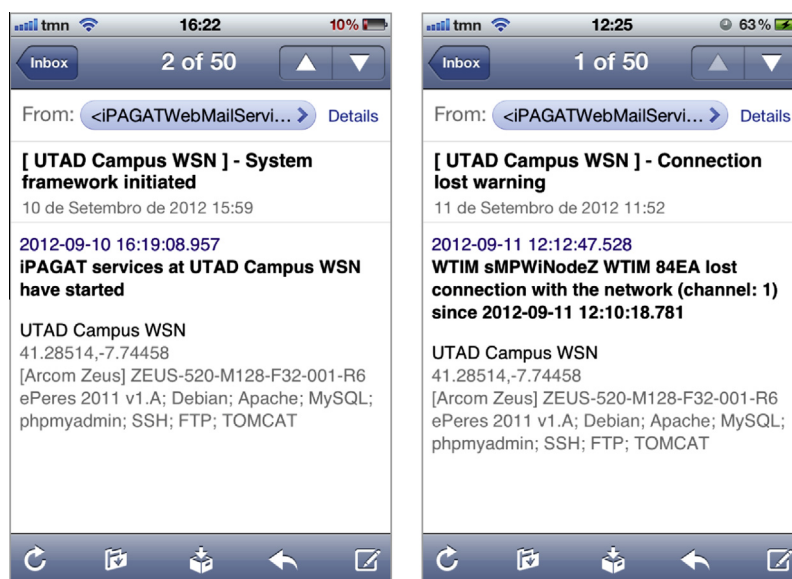

Fig. 16. Examples of automatic warning messages sent by iPAGAT and triggered when specific conditions occur. The messages can be sent by e-mail.

These sequences of events clearly show that normalization of the command sending procedures and data reception by all network elements is an enormous advantage that follows from the application of the IEEE 1451 family of standards. The implementation of TC in the WTIM considerably simplifies the tasks of designing, implementing and managing heterogeneous sensor networks, such as those used in PA/PV.

The implementation of the NCAP as part of iPAGAT made available all of its services and potential. An example is the iPAGAT alarm or warning system. We explored it to implement a message service that allows the automatic sending of e-mail reports about the iPAGAT activities. This may include issues reported by the 1451 subsystem or ZigBee. Fig. 16 illustrates two such warning messages: one is triggered when the iPAGAT is powered up, the other is when the communication with a WTIM is lost.

## 6. Discussion

The IEEE 1451 family of standards is very comprehensive but also very complex, a fact that has not always helped to make it quickly and widely adopted. However, despite the perceived complexity of these standards, they do provide a number of important advantages which make the implementation effort worthwhile.

We have already discussed some of the IEEE 1451 advantages in the context of PA/PV. The authors have a long term interest in PA/PV, mainly targeted to the Douro region in the Northeast of Portugal, one of the oldest (if not the oldest) demarcated wine-producing regions in Europe. The unique characteristics of the region, the technical challenges set by PA/PV and its important benefits (environmental, economical, etc.) have made our task both difficult and interesting.

This article is one in a series of works that the group has carried out (Morais et al., 2008a,b; Cunha et al., 2010; Peres et al., 2011). The technological solutions that we have described provide added value in PA/PV, particularly in reference to the study of variability in PA/PV practices. We have considered topics ranging from power issues (energy harvesting, power management, etc.) to networking issues (overall architecture, software, hardware). More recently, increasingly aware of the complexity and costs hidden in the deployment, management and maintenance of heterogeneous WSN, we came to appreciate normalized procedures that could

simplify these tasks. This work is considered by its authors as the first practical, full IEEE 1451 application in PA/PV and a privileged framework under which new applications can be easily tried.

As far as we know, this is the first time that the IEEE 1451 standards are incorporated in already existing devices, as a way of creating an open framework for interoperability. Although analog sensors are not intrinsically compatible with the IEEE 1451 standards, the combination iPAGAT/NCAP allows the creation of smart, easy-to-configure systems. Each wireless data acquisition platform becomes a sensor node (WTIM) with a smart TC, replacing multiple isolated sensors. The addition or removal of sensors or actuators in a totally automatic way is still limited by the WTIM hardware, but with products in which sensors are already embedded, the entire configuration process can proceed according to the IEEE 1451 standard. This allows for the development of software components (drivers) for sensor networks. As a result of the lessons learned from this work, we are now considering the specification of an interface of reconfigurable hardware under the command of the WTIM, which might allow the connection of an analog sensor and the remote configuration of the system for its incorporation.

## 7. Conclusions

One of the conclusions that can be extracted from our study is that IEEE 1451 is powerful when correctly integrated in devices that acquire, store and process heterogeneous data. The incorporation of IEEE 1451 services in the data acquisition devices allows the use of TEDS in all sensors, significantly simplifying the configuration procedures. The selection, at the NCAP level, of the sensors associated with each WTIM is enough to make “plug-and-play” a reality.

In our implementation, we have found that the module that interacts with the transducers is very important. It complements the work very well since it allows the automatic configuration of the interfaced devices. Depending on the TEDS of the transducer, the hardware of the acquisition platform can be configured to accommodate the selected sensor. We have found that this property is particularly useful and important, given the wide range of output types that sensors in PA/PV may exhibit.

Another important conclusion extracted from this work is that a full implementation of the complex set of IEEE 1451 standards is

possible for WSN based on 802.11, 802.15.4, Bluetooth, ZigBee, and 6LoWPAN as cited in the references, but may be difficult for today's ultra-low power embedded system technology. This may change in the near future as the technology evolves. However, the standardization is still crucial for the management of heterogeneous data. The simplicity in handling the data collected by WSN that support IEEE 1451 over IEEE 802.15.4/ZigBee networks shows very clearly that the IEEE 1451 family of standards is very well suited to the universe of PA/PV and to meet its needs.

### Acknowledgements

The authors would like to acknowledge the Portuguese Foundation of Science and Technology (FCT) that partially sponsors this research work through the scholarship reference SFRH/BD/38759/2007.

### References

- Barrero, F., Guevara, J.A., Vargas, E., Toral, S., Vargas, M., in press. Networked transducers in intelligent transportation systems based on the IEEE 1451 standard. *Computer Standards & Interfaces*, (Corrected Proof).
- Camilli, A., Cugnasca, C.E., Saraiva, A.M., Hirakawa, A.R., Corrêa, P.L., 2007. From wireless sensors to field mapping: anatomy of an application for precision agriculture. *Computers and Electronics in Agriculture* 58 (1), 25–36.
- Chen, C., Helal, A., Julu 2009. Device integration in SODA using the device description language. In: Ninth Annual International Symposium on Applications and the Internet, 2009. SAINT '09. pp. 100–106.
- Chen, C., Helal, S., 2008. Sifting Through the Jungle of Sensor Standards. *IEEE Pervasive Computing* 7 (4), 84–88.
- Cunha, C.R., Peres, E., Morais, R., Oliveira, A.A., Matos, S.G., Fernandes, M.A., Ferreira, P., Reis, M., 2010. The use of mobile devices with multi-tag technologies for an overall contextualized vineyard management. *Computers and Electronics in Agriculture* 73 (2), 154–164.
- Higuera, J., Polo, J., February 2010. Understanding the IEEE 1451 standard in 6LoWPAN sensor networks. In: *Sensors Applications Symposium (SAS)*, 2010 IEEE, pp. 189–193.
- Higuera, J., Polo, J., Gasulla, M., February 2009. A Zigbee wireless sensor network compliant with the IEEE1451 standard. In: *Sensors Applications Symposium*, 2009. SAS 2009. IEEE. pp. 309–313.
- Hu, P., Robinson, R., Indulska, J., December 2007. Sensor standards: overview and experiences. In: 3rd International Conference on Intelligent Sensors, Sensor Networks and Information, 2007. ISSNIP 2007, pp. 485–490.
- Lee, K., 2008. From the editor's bench – smart and wireless sensor standards for distributed measurements. *IEEE Instrumentation Measurement Magazine* 11 (2), 6.
- Matos, S., Fernandes, M.A., López, J.A., Soto, F., Reis, M.J.C.S., Morais, R., July 2012. An interactive GUI tool to create and validate IEEE 1451 Smart Sensors TEDS. In: *Proceedings of de Seminario Anual de Automática, Electrónica Industrial e Instrumentación 2012, SAAEI'2012*. Guimarães, Portugal, pp. 510–515.
- Morais, R., Fernandes, M.A., Matos, S.G., Serôdio, C., Ferreira, P., Reis, M., 2008a. A ZigBee multi-powered wireless acquisition device for remote sensing applications in precision viticulture. *Computers and Electronics in Agriculture* 62 (2), 94–106.
- Morais, R., Matos, S.G., Fernandes, M.A., Valente, A.L.G., Soares, S.F.S.P., Ferreira, P.J.S.G., Reis, M.J.C.S., 2008b. Sun, wind and water flow as energy supply for small stationary data acquisition platforms. *Computers and Electronics in Agriculture* 64, 120–132.
- Nemeth-Johannes, J., Sweetser, V., Sweetser, D., September 2007. Implementation of an IEEE-1451.0/1451.5 compliant wireless sensor module. In: *Autotestcon*, 2007 IEEE. pp. 364–371.
- Oostdyk, R., Mata, C., Perotti, J., 2006. A Kennedy Space Center implementation of IEEE 1451 networked smart sensors and lessons learned. In: *Aerospace Conference*, 2006 IEEE. pp. 1–20.
- Peres, E., Fernandes, M.A., Morais, R., Cunha, C.R., López, J.A., Matos, S.R., Ferreira, P., Reis, M., 2011. An autonomous intelligent gateway infrastructure for in-field processing in precision viticulture. *Computers and Electronics in Agriculture* 78 (2), 176–187.
- Seng, R., Lee, K., Song, E., May 2011. An implementation of a wireless sensor network based on IEEE 1451.0 and 1451.5 6LoWPAN standards. In: *Instrumentation and Measurement Technology Conference (I2MTC)*, 2011 IEEE. pp. 1–6.
- Song, E., Lee, K., 2007. Smart transducer web services based on the IEEE 1451.0 standard. In: *Instrumentation and Measurement Technology Conference Proceedings*, 2007. IMTC 2007. IEEE, pp. 1–6.
- Song, E., Lee, K., 2008. Sensor Network based on IEEE 1451.0 and IEEE p1451.2-RS232. In: *Instrumentation and Measurement Technology Conference Proceedings*, 2008. IMTC 2008. IEEE, pp. 1728–1733.
- Tani, F.K., Cugnasca, C.E., 2005. Agriculture and the IEEE 1451 smart transducer interface standard. In: *EFITA/WCCA 2005 JOINT CONFERENCE*, Proceedings. University of Trás-os-Montes and Alto Douro, pp. 1341–1348.
- Wei, J., Zhang, N., Wang, N., Lenhart, D., Neilsen, M., Mizuno, M., 2005. Use of the “smart transducer” concept and IEEE 1451 standards in system integration for precision agriculture. *Computers and Electronics in Agriculture* 48 (3), 245–255.
- Wiczor, J., Lee, K., 2005. A Unifying Standard for Interfacing Transducers to Networks – IEEE 1451.0. Presented at ISA Expo 2005, Chicago, IL.
- Wobschall, D., Stepanenko, A., Maykiv, I., Kochan, R., Sachenko, A., Kochan, V., 2009. A multi-port serial NCAP using the IEEE 1451 smart transducer standard. In: *Sensors Applications Symposium*, 2009. SAS 2009. IEEE, pp. 293–297.