

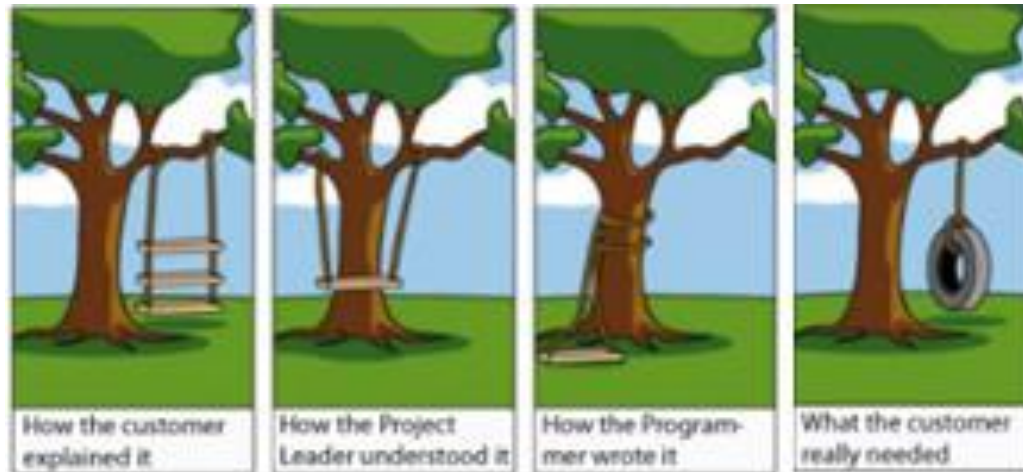

Design of Interactive Systems

Human-Centered design of interactive systems and Usability Engineering Lifecycle



The problem of interactive systems design...

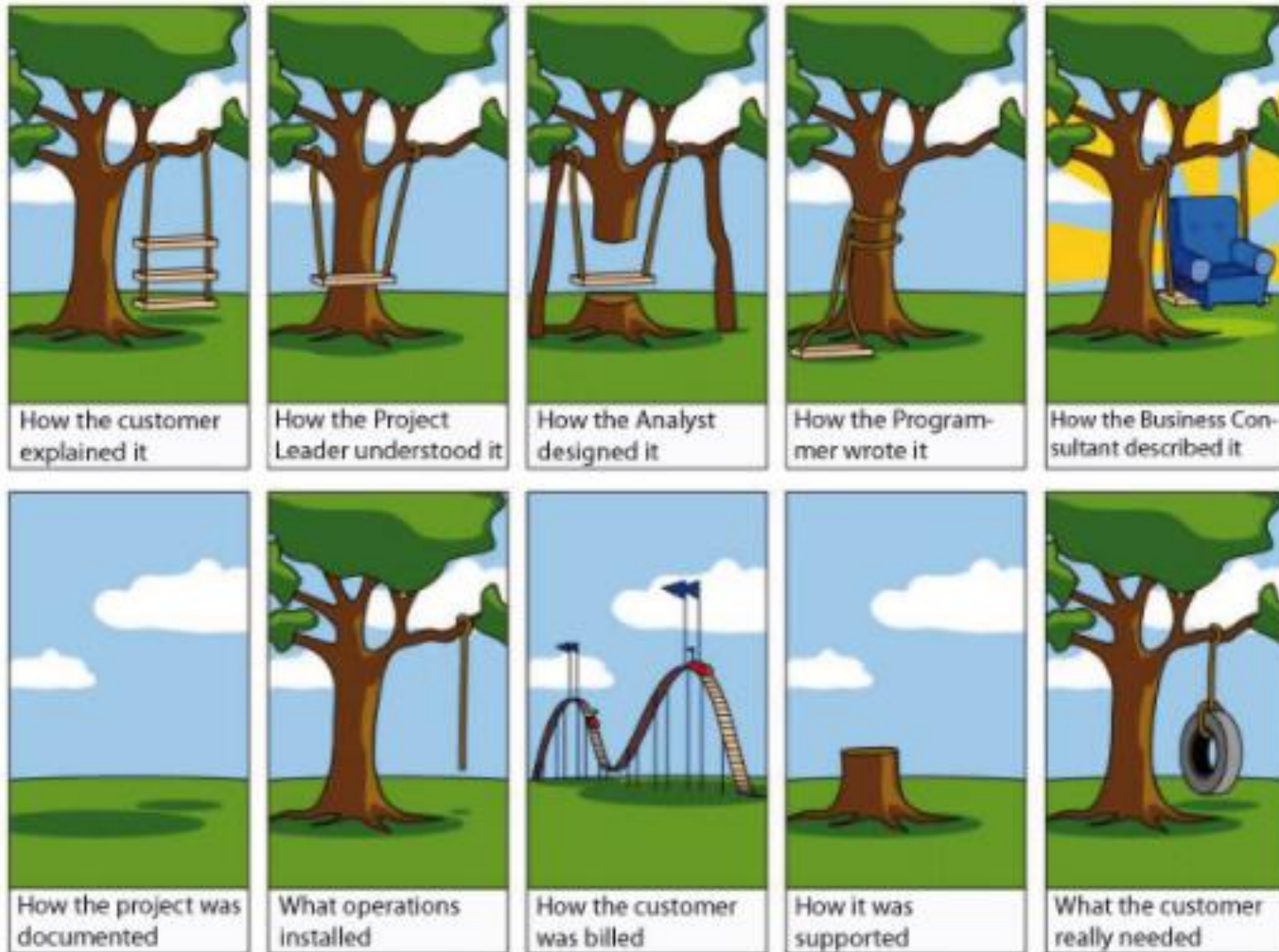

[Proper requirements management is fundamental ...](#)

**Evaluation is very important tool but cannot be the only one ...
We need good design methods...**

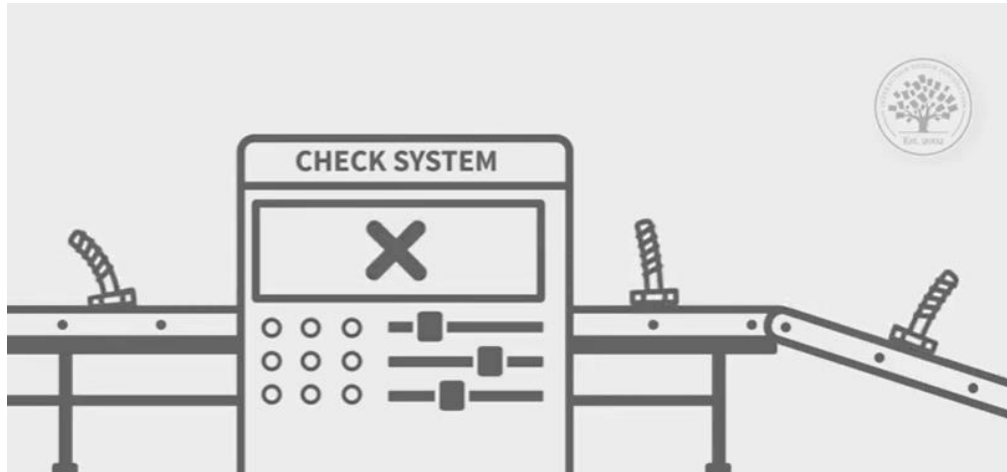

<https://www.youtube.com/watch?v=SC7KL-TGe4s>

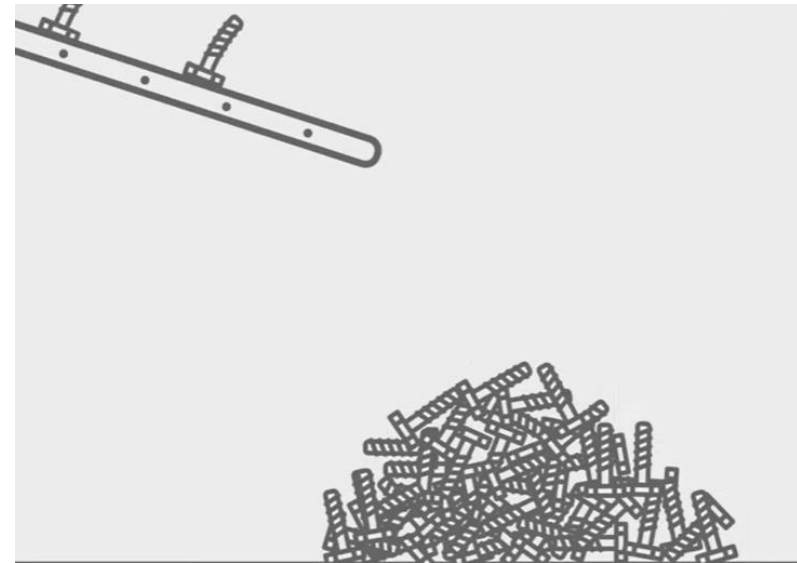

What is Human-Centered Design of interactive systems?

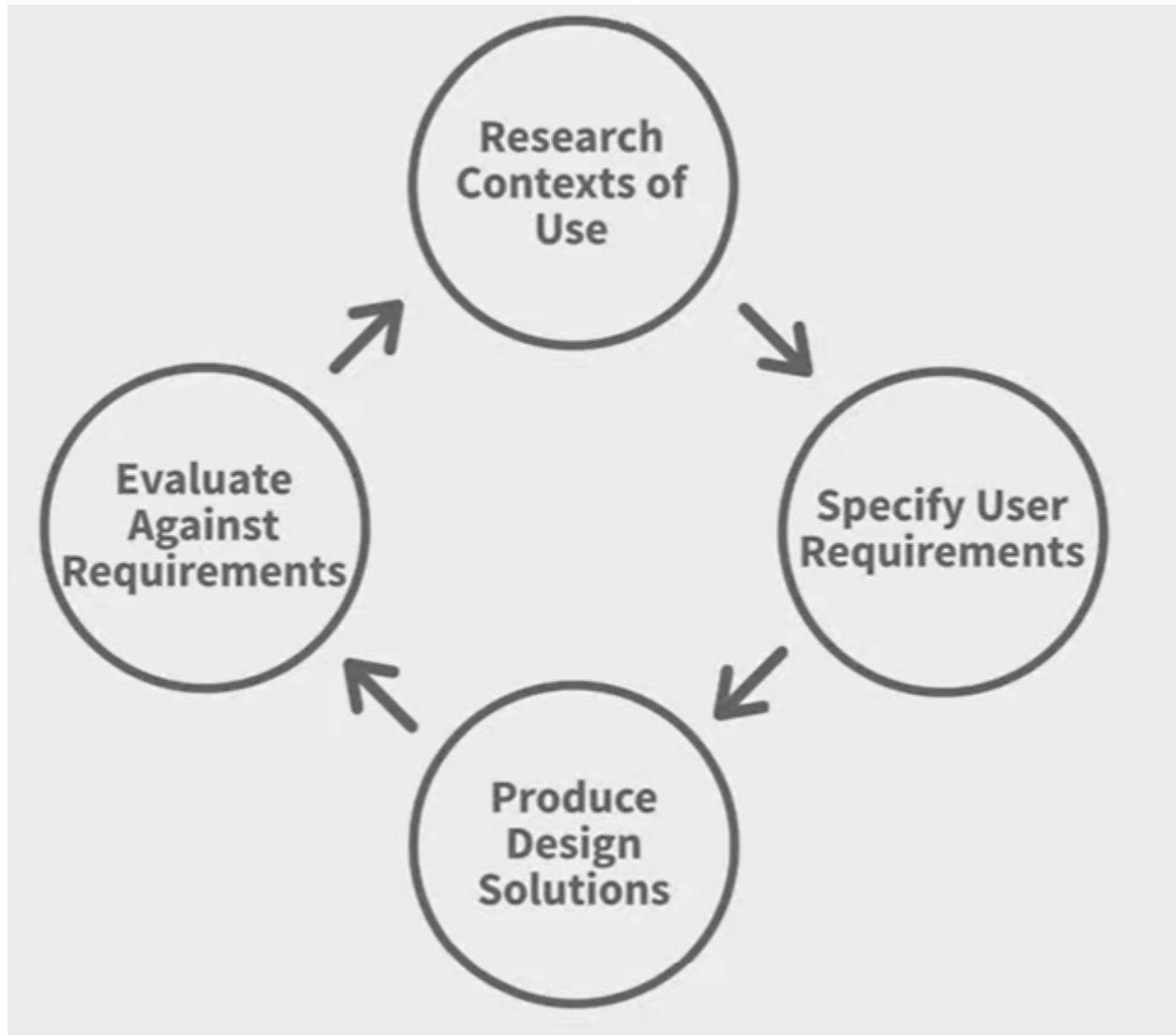

https://www.youtube.com/watch?v=KkUor_NTuDA

Human-Centred Design (HCD)

- **Approach to systems design and development** that aims to make interactive systems more usable by focusing on the use of the system and applying human factors/ergonomics and usability knowledge and techniques
- “**human-centred design**” is preferable to “user-centred design”; emphasizing it also impacts on other stakeholders (not just users)
- In practice, are often used synonymously

<https://www.iso.org/obp/ui/#iso:std:iso:9241:-210:ed-2:v1:en>

Benefits of Human-Centred Design

- Usable systems can provide a number of benefits:
 - improved productivity,
 - enhanced user well-being,
 - avoidance of stress,
 - increased accessibility,
 - reduced risk of harm.

Benefits of Human-centered design (cont.)

- Following the best practices, helps to identify challenges upfront so that a solution can be found early
- By putting a larger emphasis on principles and practices, iterative improvements can be made and avoid costly large scale rework
- The “10%” rules:
 - 10% of IT staff should be user experience (UX) professionals
 - 10% of budget dedicated to UX.

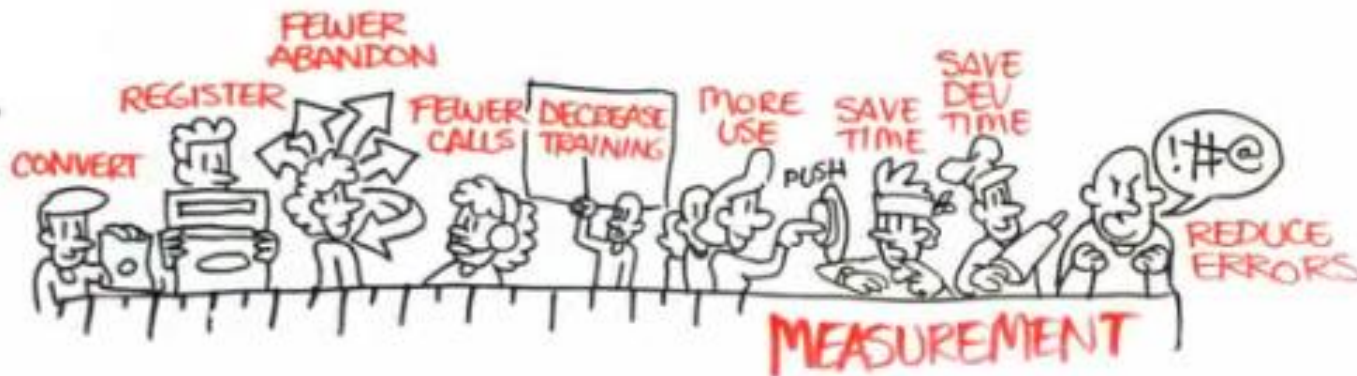

Human-Centred Design involves

- **Understanding users' needs, motivations, contexts and activities**
- Understanding business, technical, and domain opportunities, requirements, and constraints
- Using this knowledge as a grounds to create products whose form, content, and behavior is **useful, usable, economically viable and technically feasible**

- ISO standard 13407 (1999) - *Human centered design processes for interactive systems*:

"Human-centered design is an approach to interactive system development that focuses specifically on making systems usable. It is a multi-disciplinary activity."

- There are **several** proposals of HCD methodologies
- All are **iterative**
- And **include usability evaluation in iterations**

We must consider the situation at hand and ponder which are the best fitting and how to use them

<https://www.w3.org/WAI/redesign/ucd>

<http://www.usability.gov/how-to-and-tools/methods/user-research/index.html>

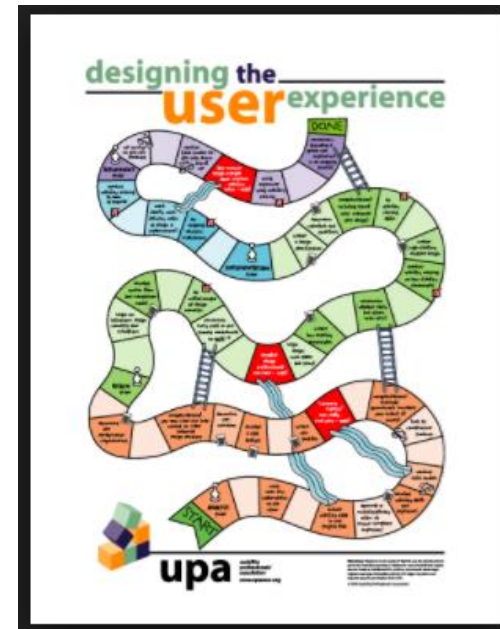

- Standards evolve:
- [ISO 9241-210:2019](#)
Ergonomics of human-system interaction — Part 210:
Human-centred design for interactive systems
- helps to identify and plan effective and timely human-centred design activities
- complements existing systems design approaches
- It can be incorporated in approaches as diverse as:
 - object-oriented,
 - waterfall,
 - rapid application development
- The principles of human-centred design and the related activities have not changed substantially since [ISO 13407](#) and have been **validated by ten years of application.**

A study about why IT projects fail (and several causes are avoidable using adequate HCD methods)

Comparing with the situation in aviation an **IT accident** may be defined as:

“project with significant damage, e.g. large cost or schedule overrun, failing business goals, low usability, etc.”

Five accident investigations of large government IT projects in Denmark

Identified 37 different causes, each causing damage to one or more projects, e.g.

- surprises with system integration
- wrong estimate of human performance

Only one cause related to programming

Proposes 22 cures that in combination could have prevented most of the damages
Half are familiar to developers, but were ignored in the project (e.g. usability test)

Some causes for IT projects failures

(and several causes are avoidable using adequate HCD/UCD methods)

| | |
|---|--|
| Analysis | |
| Doesn't identify user needs and win-win | ← Study as-is and plan to-be |
| Requirements don't cover customer needs | |
| Describes solution in detail. No freedom to supplier | ← Problem oriented requirements (SL-07) |
| Makes heavy demands and believes it is for free | |
| Oversells technology, e.g. SOA, web-based | ← Plan to-be, SL-07 reqs (sections B1 and C) |
| Multi-vendor strategy - supplier independent ! ? | |
| Wants everything at once, e.g. cover all types of debt | ← |
| Doesn't plan the new work processes | |
| No feasible solution, e.g. data missing, performance dubious. | |
| Surprising rule complexity. | |
| Design | |
| Doesn't ensure usability, even when they know how | ← Early prototypes & usability tests |
| Designs user screens too late | |
| Accepts the solution description without understanding it | |
| Cannot see how far the supplier is | |
| Test | |
| Deploys the system with insufficient testing | ← Pilot test, Ask expert developers |
| Deployment | |
| Deploys system with insufficient support/training | ← Usability tests, Pilot test, Deploy part-by-part |
| The system is not used as intended | |
| Wrong estimate of human performance | |
| | ← Observe at pilot test, Follow-up study |
| | ← Check at POC, Check at pilot test |

Iteration

- A key characteristic of HCD enables continual refinement through rapid prototyping and testing through repetition:
 - Observe and study,
 - Decide what the problem might be
 - Determine which parts of the design work and which don't

iterate again...

- **Fosters getting the requirements right**

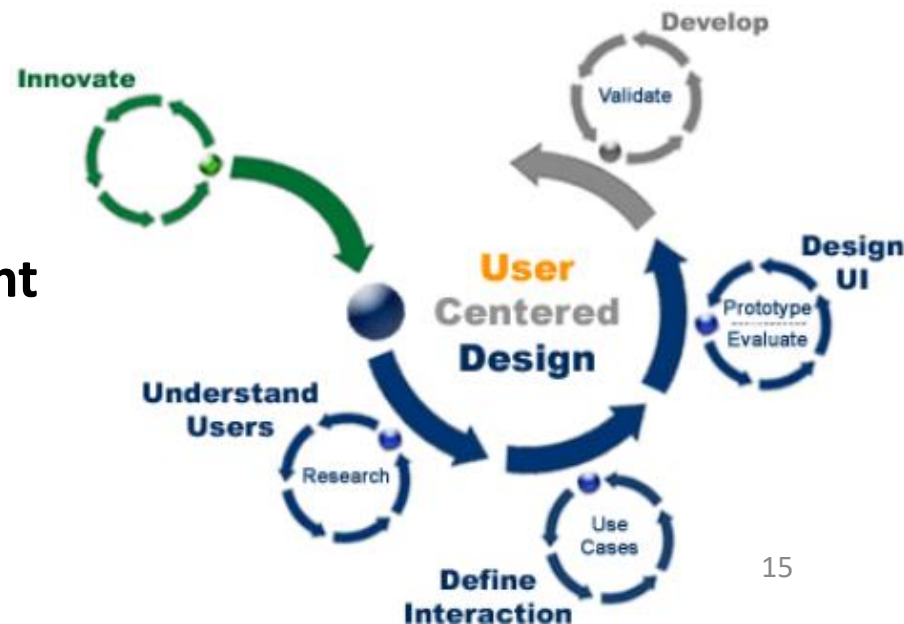

User Interface design

from a S/W engineering perspective
is iterative...

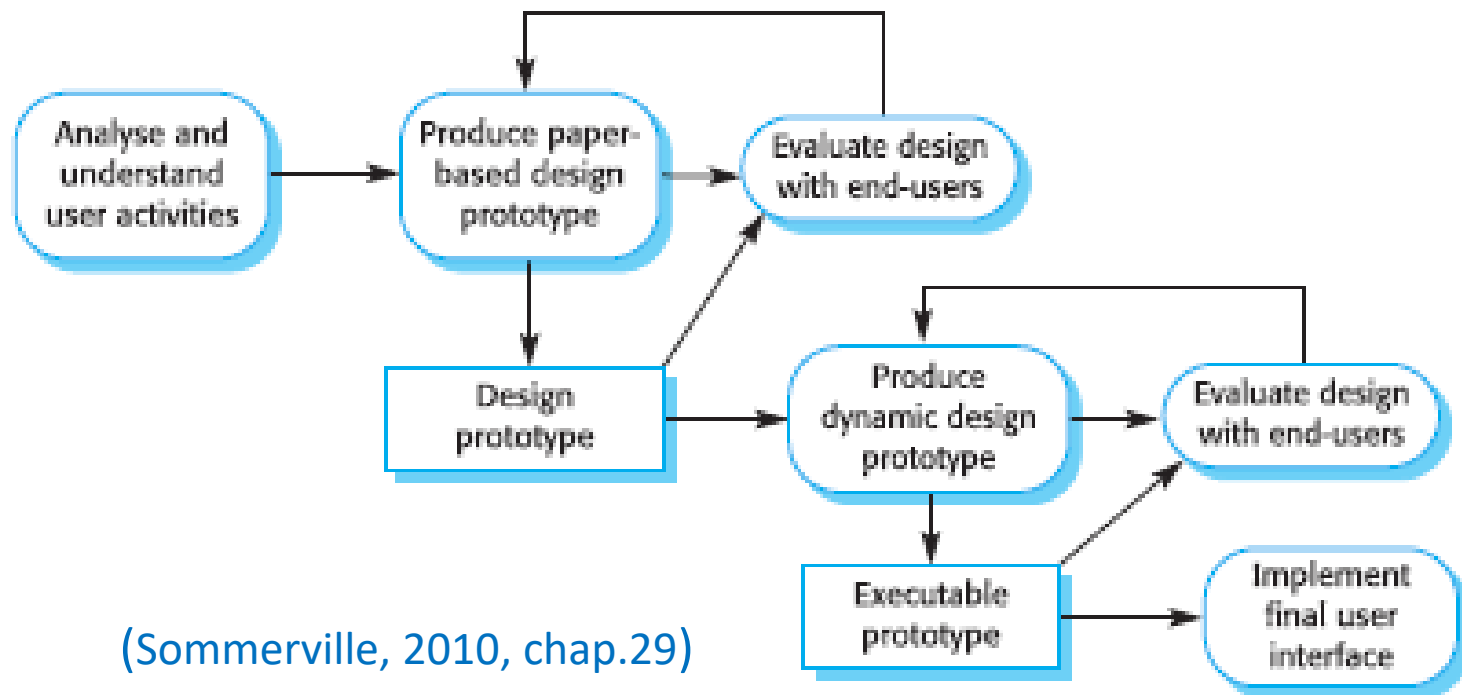

(Sommerville, 2010, chap.29)

Examples of several approaches

- The Usability Engineering Lifecycle ([Mayhew, 1999](#))
- Goal-directed design ([Cooper, 2007](#))
- Activity-oriented design ([Norman, 2013](#))
- Etc.

One of the first Human-Centered Design approaches:

The Usability Engineering Lifecycle

(Mayhew, 1999)

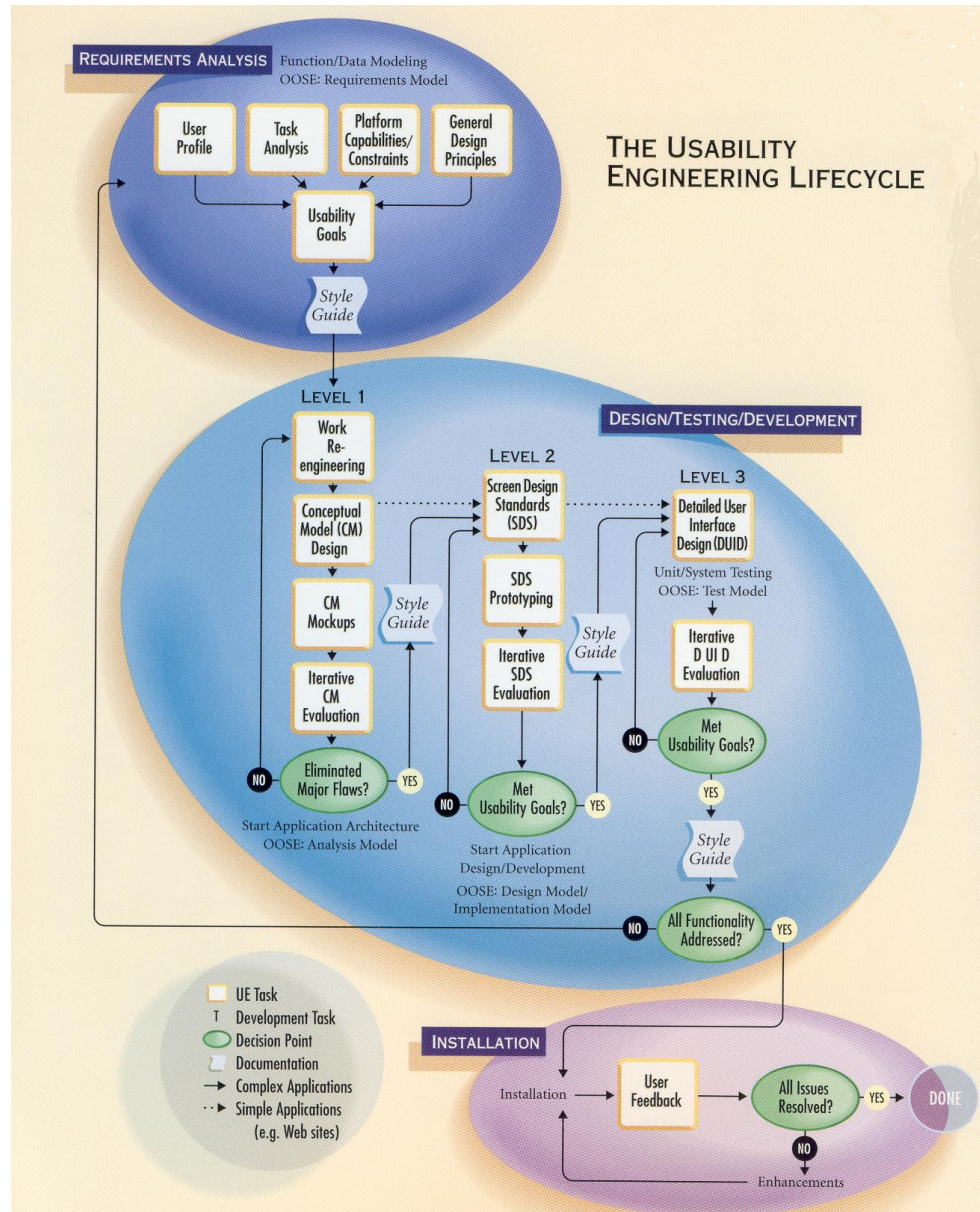

Requirement Analysis

User Profiles

Establish user characteristics important for UI design

Contextual Task Analysis

Obtain a user-centered model of work as it is currently done; extract the product usability requirements

Usability Goal Setting

Establish specific quantitative and qualitative usability goals to drive UI design

Platform Capabilities and Constraints

Establish capabilities and constraints of the technology platform which limit UI design alternatives

General Design Principles

Identify principles and guidelines that may be relevant for the product under development

Design, Testing, Development – Level 2

Screen Design Standards

Establish a set of design standards to set the stage for detailed UI Design

Screen Design Standards Prototyping

Support the evaluation, refinement and validation of the Screen Design Standards

Iterative Screen Design Standards Evaluation

Evaluate, refine, and validate the Screen Design Standards

Style Guide Development

Document the Conceptual Model Design, the Screen Design Standards and the output of Requirement Analysis

Design, Testing, Development – Level 3

Detailed User Interface Design

Design the complete, detailed product User Interface

Iterative User Interface Evaluation

Evaluate, refine, and validate key subsets of the detailed User Interface Design

Installation

User Feedback

Obtain usability data after a product has been installed and used

Inform the UI Design for later releases or related products

Evolution of the software development process

Early days of the S/W industry



...

Goal directed S/W development

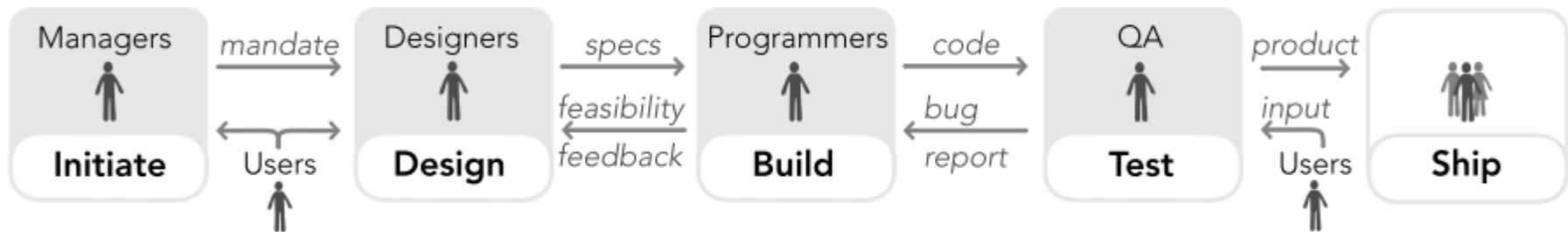

(Cooper, 2007)

Goal-directed design (Cooper, 2007)

- **Works on any platform, in any subject area, and with any users**
- **Is based on understanding the users and their desired end-state**
- Not on any particular technology
- It involves **personas and workflows**

Activity-based design (Norman, 2013)

- Let the activity define the product
- Let the conceptual model be built around the activities
- Activity is a set of tasks performed together toward a goal

It is different from task

Is a high-level structure (e.g. “go shopping”)

- Tasks are lower level components (e.g. walk to the shop, ask for a product...)

Simple Interaction design lifecycle model

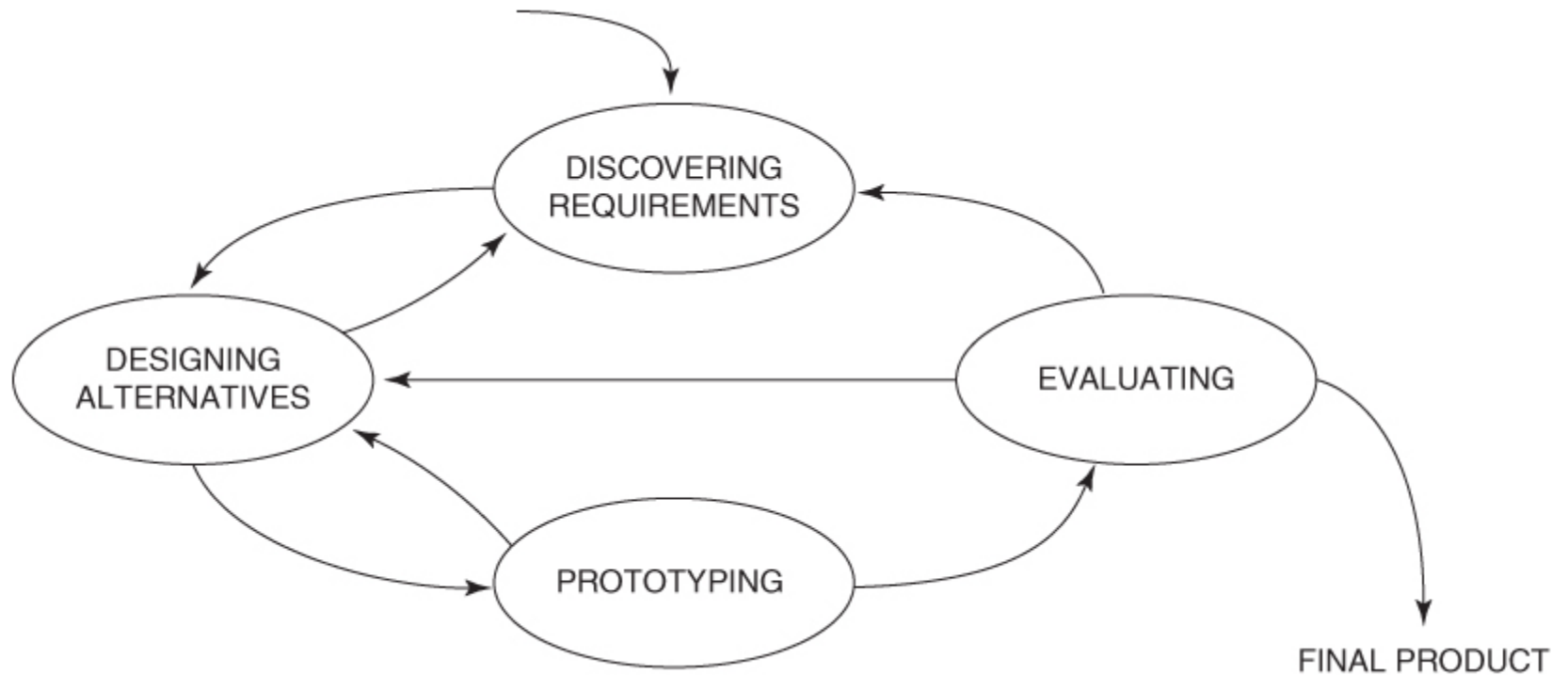

(Sharp et al, 2019)

Start by doing user research to discover requirements...

User Research Methods

There are **a lot of methods**; we must consider the situation at hand to select and adapt the ones we use:

- Context interviews
- Focus groups
- Individual interviews
- On-line surveys
- **Personas**
- **Scenarios**
- **Task analysis**
- Activity analysis
- First click tests
- ...

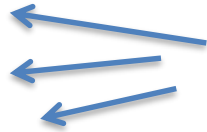

**Methods to use in the mini-project
(2nd assignment)**

<http://www.usability.gov/how-to-and-tools/methods/user-research/index.html>

Requirement analysis for the mini-project



Lab 6 - User Centered Design (UCD). 2nd Assignment

- Introduction to requirement analysis: using personas, scenarios and task analysis
- Introduction to the technologies to be used

 [How to perform a requirements analysis](#) (available in Moodle Lab classes area)

Personas and scenarios

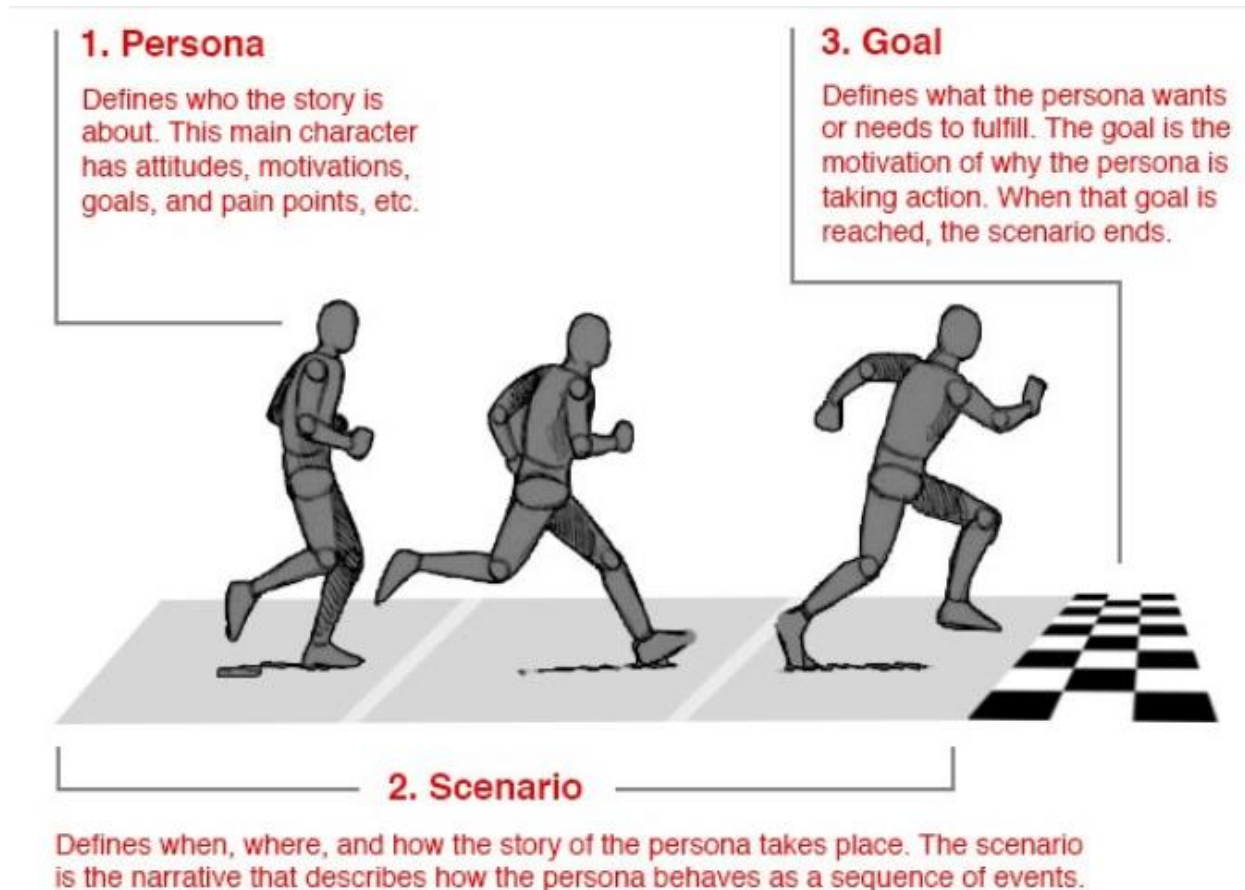

<https://www.interaction-design.org/literature/article/personas-why-and-how-you-should-use-them>

Personas

- **Fictional characters based upon user research** to represent the different user types that might use a service/product in a similar way
- make the design task less complex, and guide the ideation process
- help:
 - understand users' needs, experiences, behaviors and goals
 - step out of oneself and recognize that different people have different needs and expectations
 - uncovering universal features and functionality
 - create a good user experience for your target users



History of Personas

Stem from IT system development during the late 1990s

How to best communicate an understanding of the users?

Various concepts emerged:

user archetypes, user models, lifestyle snapshots, ...

Alan Cooper (1999) proposed personas to describe fictitious users

There is **no single definition** of what a persona should contain

Nor a unified understanding of how to apply the method

Benefits of Personas

- Offer a quick and inexpensive way to test and prioritize features throughout the development process
- Help
 - Focus decisions by adding a layer of real-world consideration
 - Stakeholders evaluate new feature ideas
 - Information architects develop informed wireframes, and interface behaviors
 - Designers create the overall look and feel
 - System engineers/developers decide which approaches to take based on user behaviors

Types of Personas

- Several types (most based on previous user research):
 - **Goal-directed** Personas (Cooper, 2007)
 - **Role-based** Personas (goals + behavior)
 - **Engaging** Personas (goals + behavior + backgrounds)
 - **Fictional** Personas (based on assumptions, not user research)
- **Fictional personas can only be used as an initial sketch of user needs**

<https://www.interaction-design.org/literature/article/personas-why-and-how-you-should-use-them>

Best Practices for Developing Personas

- Create 2-4 personas of the product/service main audiences
- Conduct user research:
 - Who are the users
 - Why are they using the system?
 - What behaviors, assumptions, and expectations?
- Develop the appropriate descriptions of each persona's: background, motivations, and expectations
- Do not include too personal information
- Be relevant and serious

Elements of a persona

- Persona Group (i.e. web manager)
- Fictional name
- Job titles and major responsibilities
- Demographics such as age, and education
- The goals and tasks they are trying to complete using the product
- Their physical, social, and technological environment

Personas have no value in themselves, until they become part of a scenario they do not have real value!

Example of a Persona

Persona: USDA Senior Manager Gatekeeper

Photo:



Goals and tasks:

Spends his work time:

- Requesting and reviewing research reports,
- preparing memos and briefs for agency heads, and
- supervising staff efforts in food safety and inspection.

Fictional name:

Matthew Johnson

Environment:

He is comfortable using a computer and refers to himself as an intermediate Internet user. He is connected via a T1 connection at work and dial-up at home. He uses email extensively and uses the web about 1.5 hours during his work day.

**Job title/
major
responsibilities:**

Program Staff Director, USDA

Demographics:

- 51 years old
- Has a Ph.D. in Agricultural Economics.

Example of using personas in VR

Model the people who will be using the VR application

Help to prevent the design from being driven by design/ engineering convenience

Personas should

- **not be too detailed**

- **be validated** in later stages

| | |
|---|--|
|  <p>Name</p> | <ul style="list-style-type: none">• Job• Experience• Activities• Attitude• Competencies• Age |
| <ul style="list-style-type: none">• Problems• Pain points• Needs• Concerns• Fears• Desires | <ul style="list-style-type: none">• Knowledge of VR• Dream VR system• Vision of VR• VR hardware access• Budget for VR• Activities that fit VR |

(Jerald, 2016)

Describe 2–4 characters representing the range of targeted users

Sketch/photo and name

Basic description of the person

| | |
|---|--|
|  <p>Name</p> | <ul style="list-style-type: none">• Job• Experience• Activities• Attitude• Competencies• Age |
| <ul style="list-style-type: none">• Problems• Pain points• Needs• Concerns• Fears• Desires | <ul style="list-style-type: none">• Knowledge of VR• Dream VR system• Vision of VR• VR hardware access• Budget for VR• Activities that fit VR |

Challenges the person has

Relation to type of system (VR in this case)

If personas are especially important (e.g., for therapy applications), then data should be carefully collected with interviews and/or questionnaires

Another example of a Persona

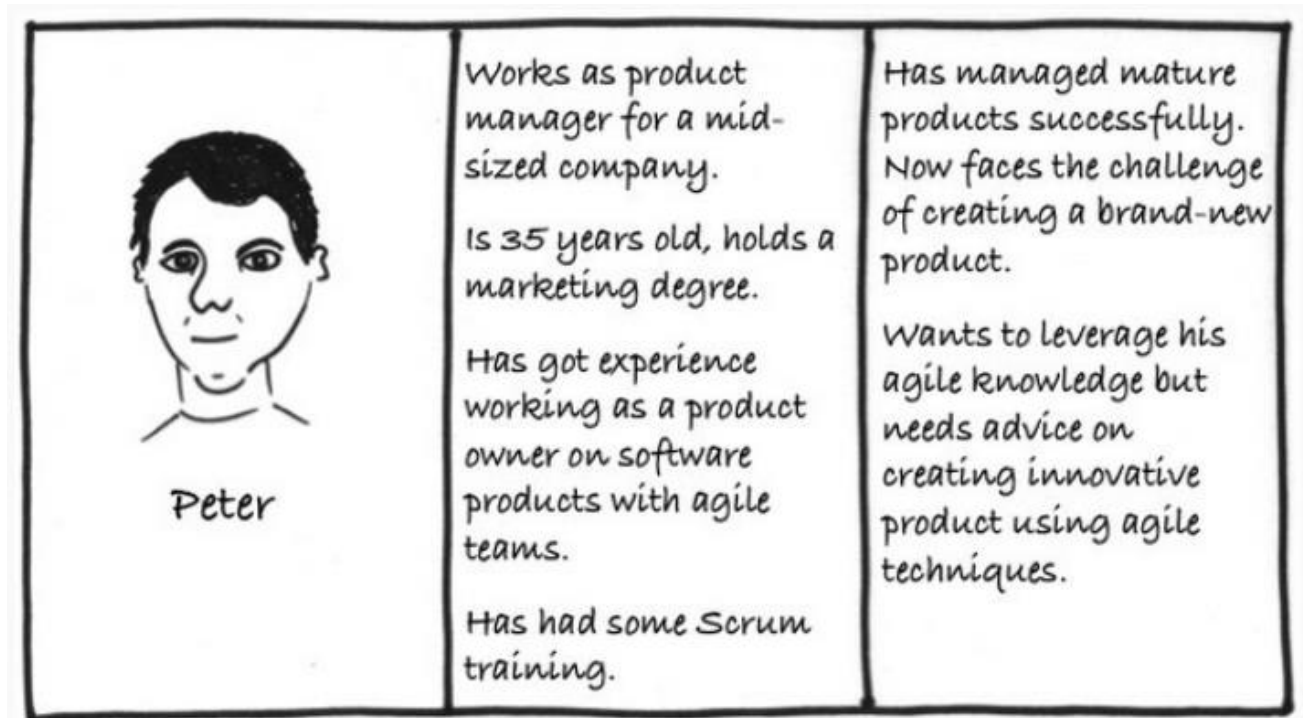

- A main difficulty of the persona method is getting the team members to use it
- The 10-step process of creating a persona can help

<https://www.interaction-design.org/literature/article/personas-why-and-how-you-should-use-them>

10 steps to Creating Personas and Scenarios (and getting them used by the team)

- 1- Collect data - and knowledge about the users
- 2- Form a hypothesis - general idea of the various users
- 3- Everyone accepts the hypothesis
- 4- Establish a number— the final number of personas
- 5- Describe the personas - to be able to develop solutions
- 6- Prepare scenarios for the personas to describe solutions
- 7- Obtain acceptance from the organization and participants
- 8- Disseminate knowledge for the participants to use them
- 9- Everyone prepares scenarios- Personas have no value in themselves
- 10- Make ongoing adjustments- revise the descriptions often

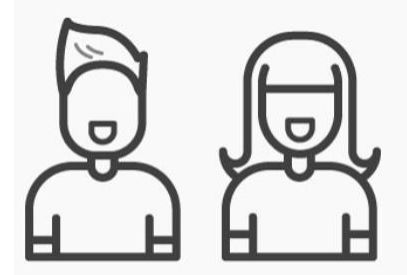

Personas: The Take Away

- Personas are **fictional characters based on user research** to help understand:
 - users' needs, and experiences
 - behaviors and goals
- Make the design task at hand less complex
- Guide the ideation processes, and help to achieve the goal of creating a good user experience for the target user group
- The 10-step process covers the entire process from the preliminary data collection, through active use, to continued development of personas.



<https://www.interaction-design.org/literature/article/personas-why-and-how-you-should-use-them>

Scenarios

- **Stories and contexts about how the user groups use a future product/service**
- Note the goals and questions to be achieved and sometimes define the possibilities of how the user(s) can achieve them on the product/service
- Scenarios are critical for
 - **designing**
 - **usability testing**

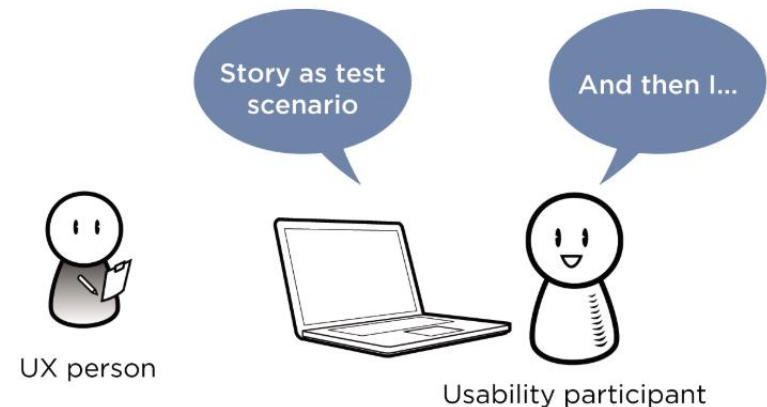

<https://www.usability.gov/how-to-and-tools/methods/scenarios.html>

<https://www.interaction-design.org/literature/topics/user-scenarios>

- Scenarios should be used in the ideation phase of a project
- Need to be ***based on research*** with users
- Do ***not*** represent ***all*** possible users
- Typically account for the ***most common*** users or user motivations
- Are commonly ***based on personas***
- Can be used to determine the most important areas to test during usability testing, and to provide guidance to the test

What to Consider When Writing Scenarios

- Good scenarios are concise but answer the following questions:
 - **Who is the user?** Use the **personas**
 - **Why does the user uses the product?** Note what motivates the user and their expectations, if any
 - **What goals does s/he have?** Use **task analysis**
 - **How can the user achieve their goals with the product?**

<https://www.usability.gov/how-to-and-tools/methods/scenarios.html>

Types of Scenarios

- **Goal/Task-based Scenarios** state only what the user wants to do

Example: You are traveling to Paris for your job next week and you want to check on the amount you can be reimbursed for meals and other expenses

- **Elaborated Scenarios** give more user story details
- **Full Scale Task Scenarios** include the steps to accomplish the task

<https://www.usability.gov/how-to-and-tools/methods/scenarios.html>

Scenarios: The Take Away

- User scenarios are a **great way of communicating the key tasks a user will perform with a system**
- They can also **help define the usability testing** regime
- To create user scenarios is a simple process and **should be used for developing and iterating interactive products**

<https://www.interaction-design.org/literature/topics/user-scenarios>



Task Analysis

- The process of **learning about ordinary users** by observing them in action to **understand in detail how they perform their tasks** and achieve their intended goals.
- Helps identify the tasks that product/service must support
- Helps support other aspects of the user-centered design process
- It is important to perform a task **analysis early in your process**, in particular prior to design work

<https://www.usability.gov/how-to-and-tools/methods/task-analysis.html>

Types and benefits of Task Analysis

- Several types 
 - Hierarchical task analysis (studied in more detail later)
 - ...
 - Cognitive task analysis
- Help support several aspects of the user-centered design process, including:
 - Requirements gathering
 - Developing structure
 - Prototyping
 - Usability testing

<https://www.usability.gov/how-to-and-tools/methods/task-analysis.html>

- **Task analysis is useful for understanding:**
 - **Users' goals** and what they are trying to achieve
 - The **steps that users currently take** to achieve their goals
 - The personal, social and cultural experiences that **users bring to the tasks**
 - The **influence of the physical environment** on the users while attempting to meet a goal

<https://www.interaction-design.org/literature/article/task-analysis-a-ux-designer-s-best-friend>

- **Task analysis may be performed:**
 - in a **more formal way** (e.g. HTA - Hierarchical Task Analysis)
or
 - in a **more informal way:**
 - using several different methods
- **First use the 11 questions (at least 1, 2, 3 and 5)**
- **Then decompose the main tasks**

Standard/Informal Questions to be answered

1. **Who is going to use the system?**
2. **What tasks do they now perform?**
3. **What new tasks are desired?**
4. How are the tasks learned?
5. **Where are the tasks performed?**
6. What is the relationship between customer and data?
7. What other tools does the user have?
8. How do users communicate with each other?
9. How often are the tasks performed?
10. What are the time constraints on the task?
11. What happens when things go wrong?

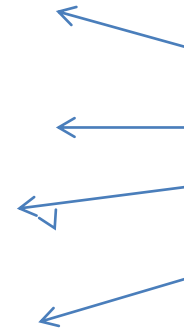

Minimum set of questions to be answered

1. Who is going to use the system?

- Use **all the information obtained previously about the users** (e.g. to develop the personas), concerning:
 - age, needs, motivations, background, experience, technology literacy, physical characteristics...



2. What tasks do they now perform?

- Identify the **tasks that users perform currently**, without using the system under development, including:
 - relative importance, frequency of performing the tasks, if they are performed by one or more users, ...

3. What new tasks are desired?

- Identify new tasks that might empower the users taking advantage of the new way of performing the tasks
- Be careful and prioritize the new tasks to support ...



5. Where are the tasks performed?

- Observe the environment where users currently perform the tasks
- Identify other activities, the type of space (office, shop floor, hospital, class room, shopping mall, ...), noise, light and dust conditions, stress level, ...

How to conduct a Task Analysis

- Decompose a high-level task into the following steps:
 - Identify the task to be analyzed
 - Break this high-level task down into 4 to 8 subtasks
 - Draw a layered task diagram of each subtasks
 - Produce a written account as well
 - Present the analysis to someone else who knows the tasks
- The decomposition level of detail should be coherent across subtasks

<http://www.usabilitybok.org/task-analysis>

Example of a Hierarchical Task Analysis

(it will be addressed later in the semester)

Diagram for the goal: warm up a furnace

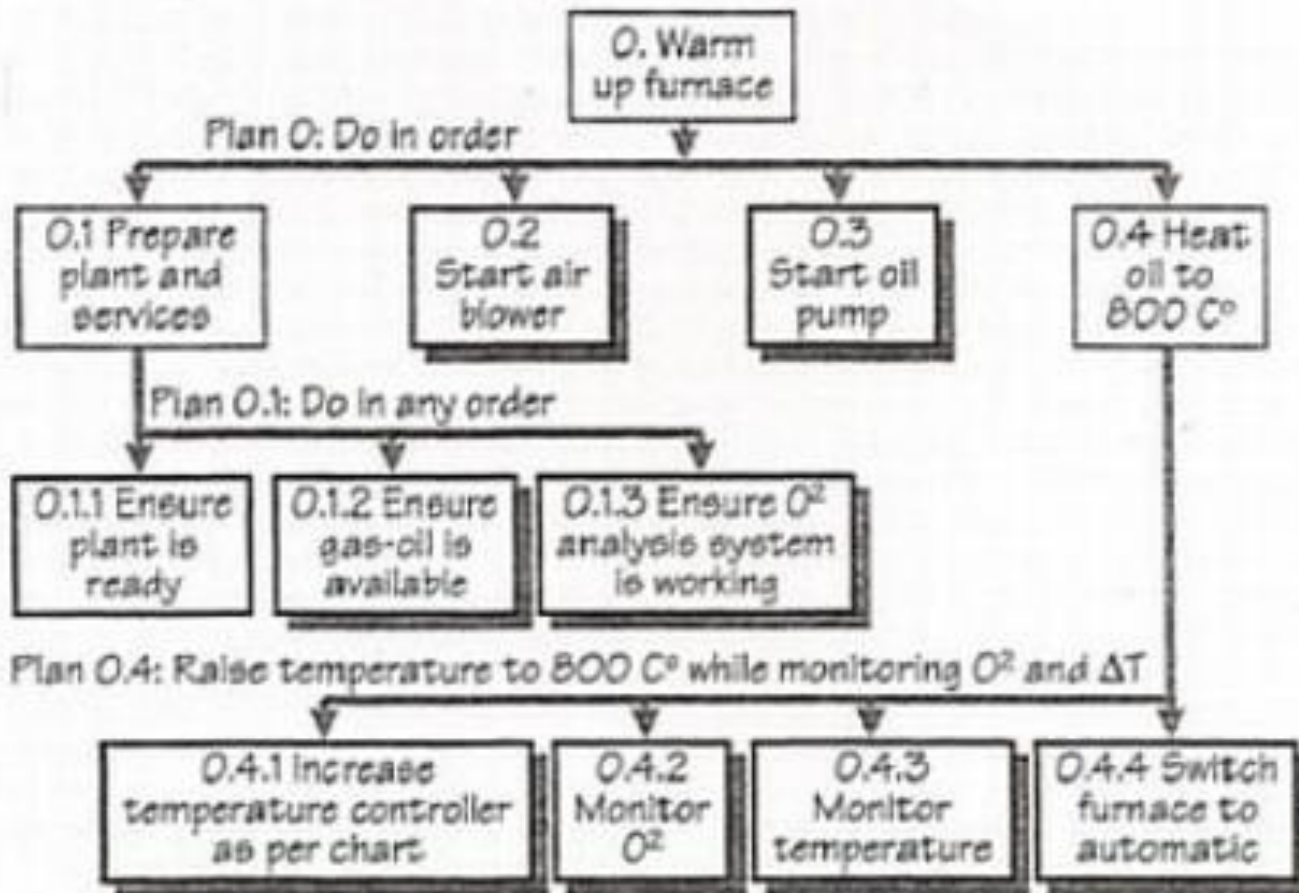

<https://www.interaction-design.org/literature/article/task-analysis-a-ux-designer-s-best-friend>

Task Analysis: The Take Away

- **Is one of the most powerful tools in UX design**
- It is not hard to get to know how to do it
- The difficult part is remembering to keep the user's perspective
- It is **useless when it is not backed by rigorous user research**
- is not a one-off process; **can be repeated** later in the process
- **It requires time, resources, people and budget. Be sure to have a sufficient amount of all**
- Like any other activity in UX design!

<https://www.interaction-design.org/literature/article/task-analysis-a-ux-designer-s-best-friend>

Other methods...

- The previous methods should be used in the 2nd assignment (mini-project)
- But there are other methods that can be used in a requirements analysis (and that you may already know...):
 - User stories
 - Use cases
 - Story boards
 - Etc.

User Stories

Emerged from agile development methods, are **short concepts or descriptions of features customers would like to see**

Should:

not go into too much detail

be written:

- from the **user's point of view**
- **with the client** and team members

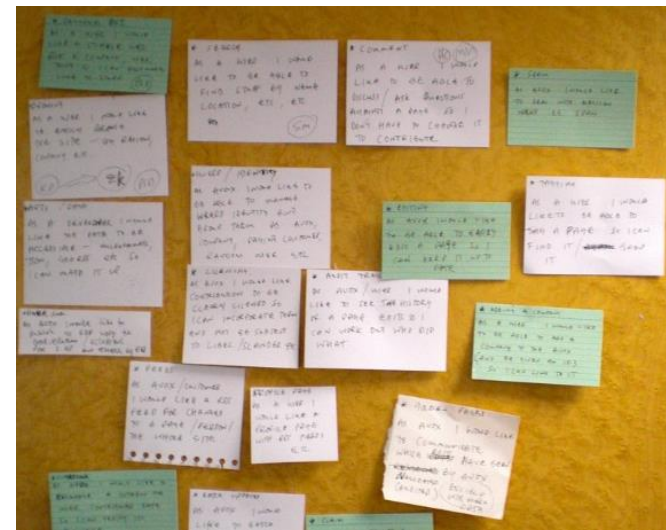

User Stories

“As a <type of user> I want <some goal>
so that <some reason>.”

Should be written with the **minimum amount of detail** necessary to fully encapsulate the value that the feature is meant to deliver

<https://manifesto.co.uk/how-much-detail-should-a-user-story-have/>

<https://www.interaction-design.org/literature/topics/user-stories>

<https://www.interaction-design.org/literature/article/user-stories-capturing-the-user-s-perspective-quickly-and-simply>

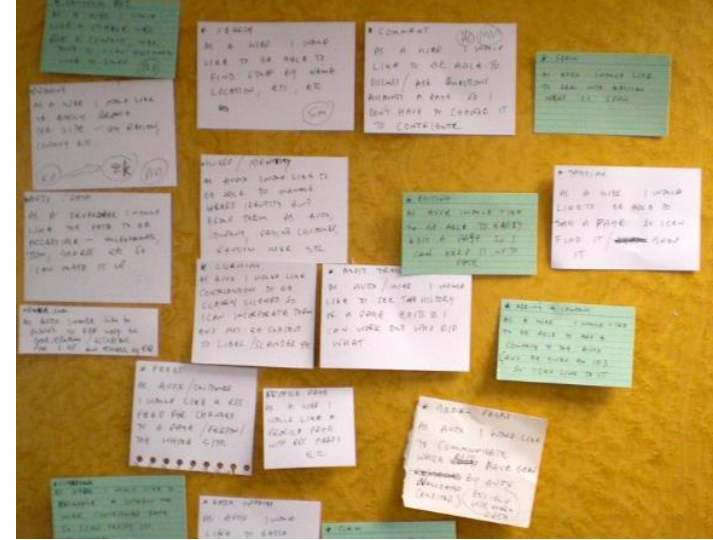

Use Cases

A common way for developers to explain user scenarios using UML

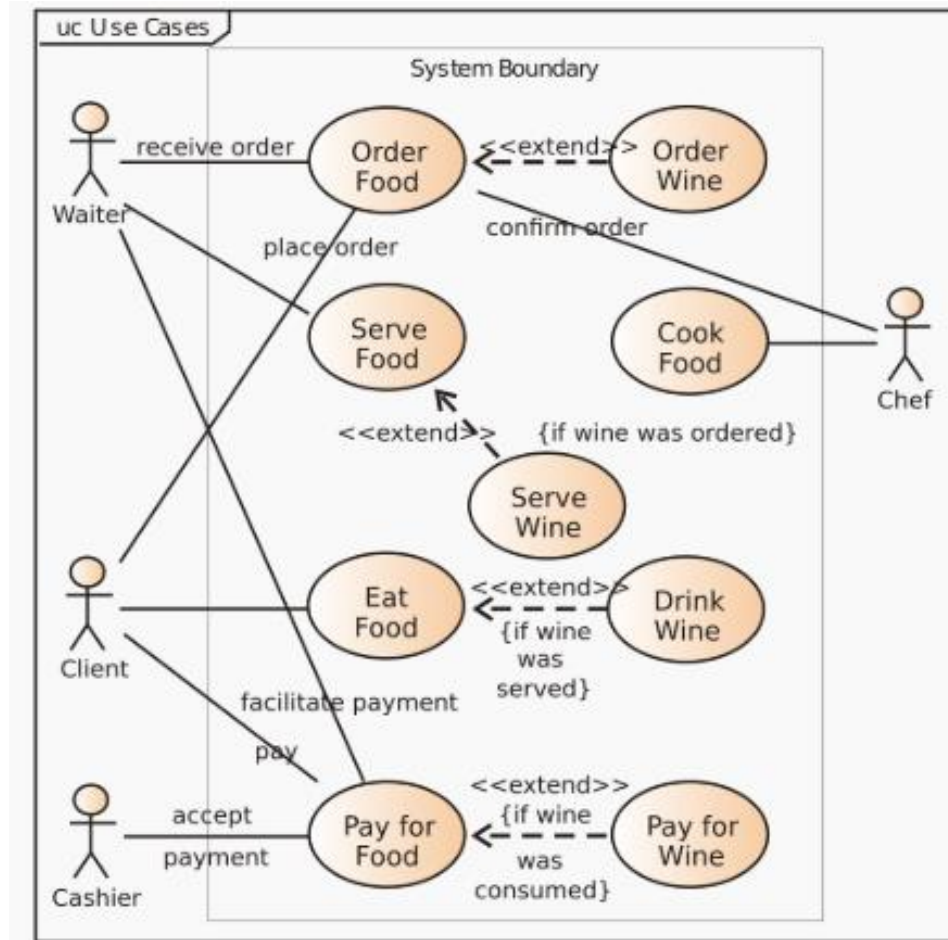

<https://www.usability.gov/how-to-and-tools/methods/use-cases.html>

Scenarios, User stories and Use cases

- Scenarios are created by user researchers to help communicate with the design team
- User stories are created by project/product managers to define the requirements prior to a sprint in agile development
- Use cases are created for developers to help with testing
- The difference in target audience means that the structure and information contained in the three approaches also varies.

Example

Scenario

“Jim, an internal medicine intern at Mount Pleasant Hospital, walks into the room of his patient, Andrew. Since Andrew stayed the night in the hospital, Jim needs to review Andrew’s medical records to see if the nurses on the night shift had checked in and recorded any changes in Andrew’s condition.”

User Story

As a doctor, I need to get up to medical date records so that I know how to proceed with my patients’ treatment

(it does not reflect the context of use)

Use case: Review Records

Actor: Doctor

Steps:

Doctor walks into room

Doctor sees patient in bed

Doctor identifies patient in bed

Doctor sees medical charts on foot of bed

Doctor gets medical charts from foot of bed

Doctor opens medical charts

Doctor reads medical charts

Doctor changes pages to continue reading

Doctor closes medical chart

<https://www.akendi.com/blog/scenarios-user-stories-and-use-casesoh-my/>

Storyboards

Are early visual forms of an experience

Derived from the film industry

Particularly useful for VR

The user can be shown directly interacting with objects

<http://usabilitybok.org/storyboard>

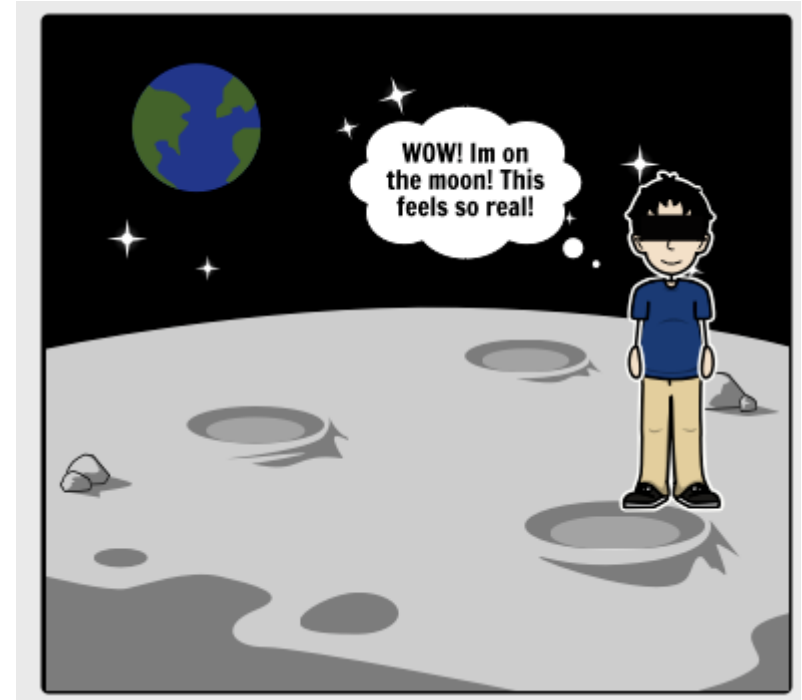

<https://www.storyboardthat.com>

Prototyping for the mini-project

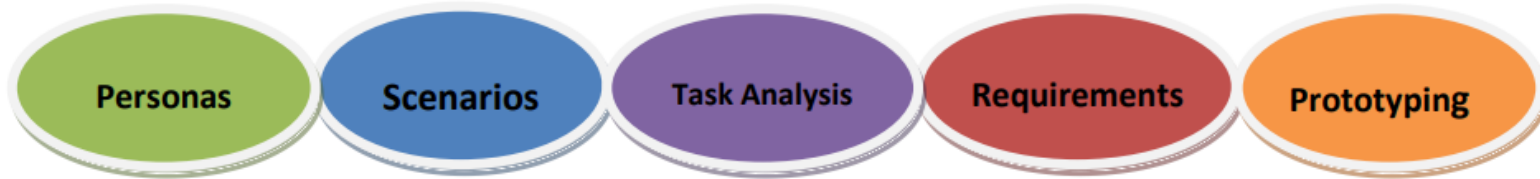

Lab 8 - Test with Low Fidelity Prototype

Each group shall prepare a usability test with a paper prototype for the application under development (test should take +/- 15min). To prepare this class, use the notes about prototyping available. Main results of this evaluation shall be reported in the final presentation.



[Notes on paper prototyping](#)

(available in Moodle Lab classes area)

Prototyping

Prototype is a **draft version** of a product to:

- **explore ideas**
- show the intention behind a feature or the **overall design concept**

before investing time and money into development

low-fidelity → high-fidelity

<https://www.usability.gov/how-to-and-tools/methods/prototyping.html>

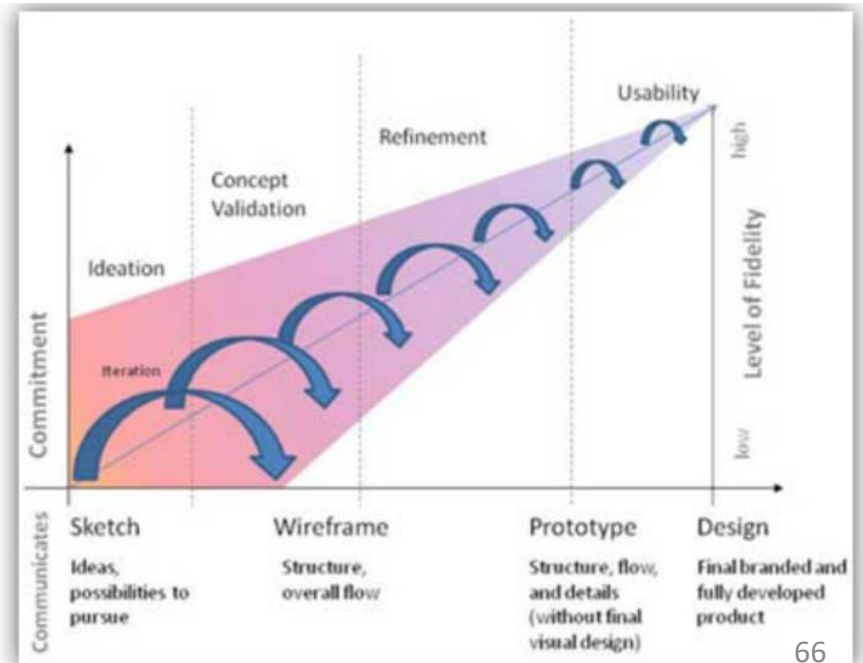

Low fidelity prototypes

- Fast and inexpensive
- Valuable to test the UI conceptual model
- Easy to modify even during user tests
- Elicit users feedback concerning general aspects
- Estimated to allow detecting up 80% of the usability issues



- Specifically adequate to get feedback concerning:

- Concepts and terminology
- Navigation
- Contents
- Functionality

Search Localization

New localization

- Change name "Mark" to "Supermarket Name"

- Change order of "City" and "Supermarket"

Recent localizations

Localization by GPS

Shopping List

Recent lists

Insert list by category

Insert list by notebook

- Insert the list above while we are adding products

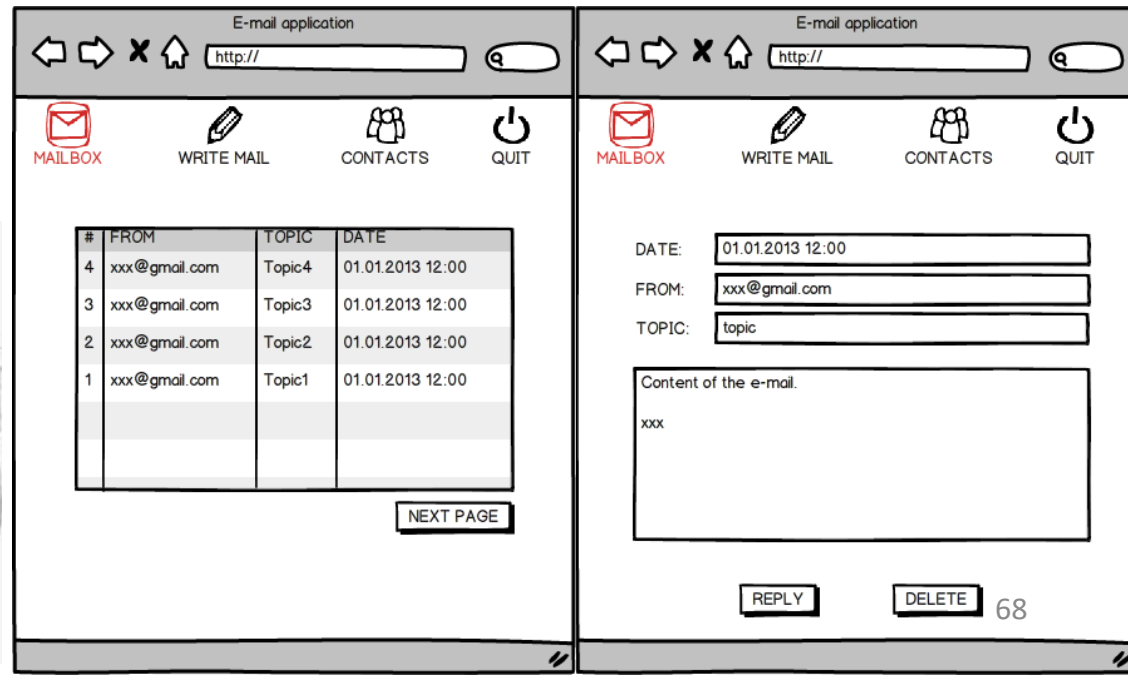
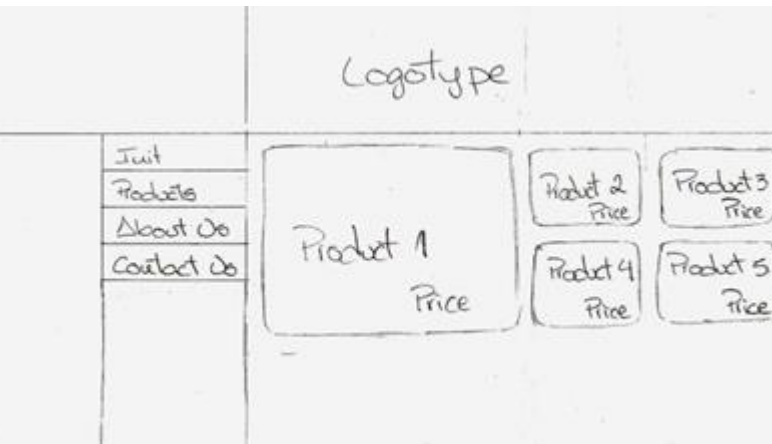

- Do not need to have much detail, nor to be very realistic, e.g.:
 - Sizes of windows, fonts, etc. don't need to be final
 - Text may be replaced by some lines
 - Images may be replaced by words
 - In general no colour is needed

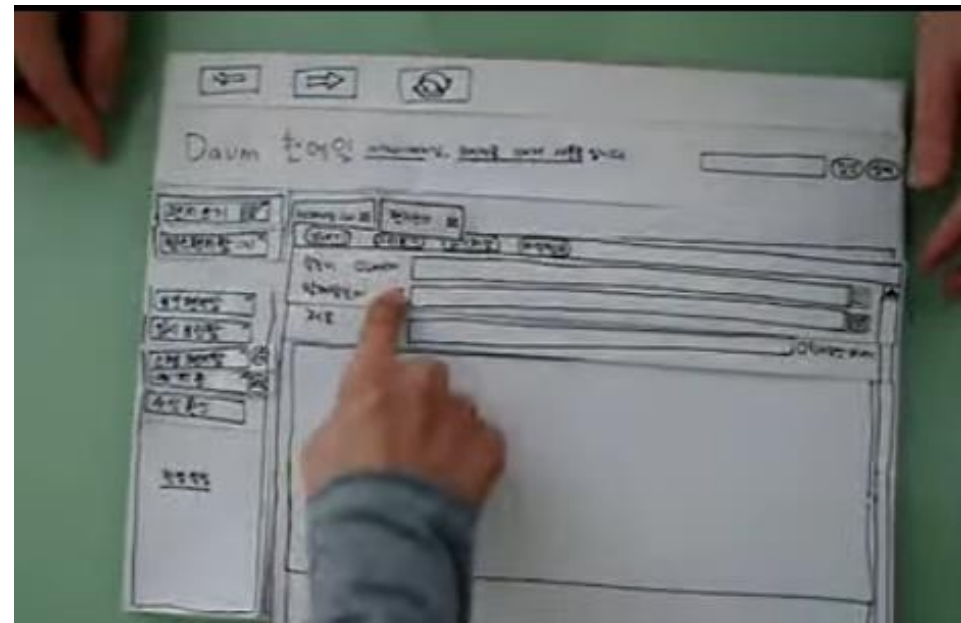

What can be used to make it?

- Paper, pens, markers, ...
- Applications such as:
 - Balsamiq
 - Pencil
 - Proto.io
 - Etc.

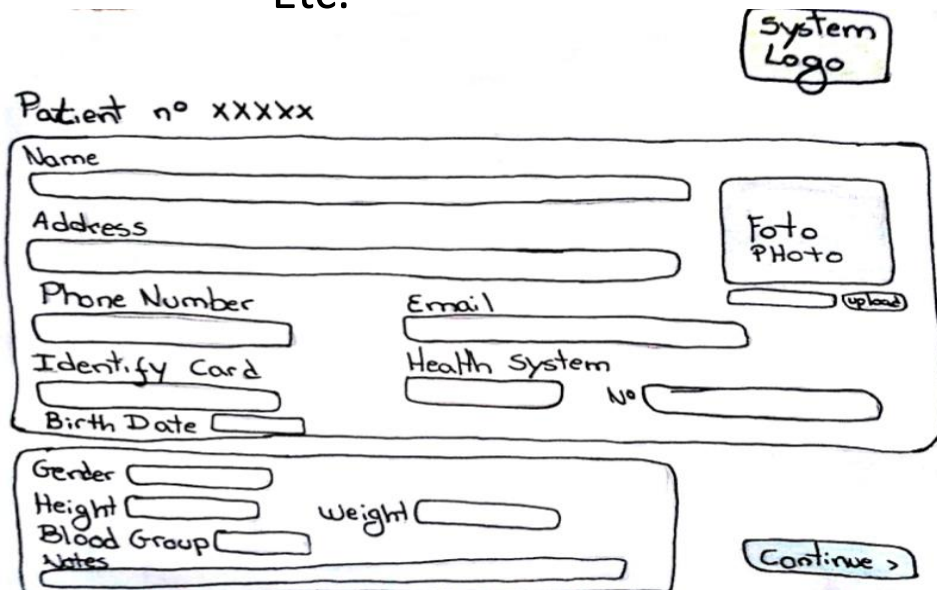
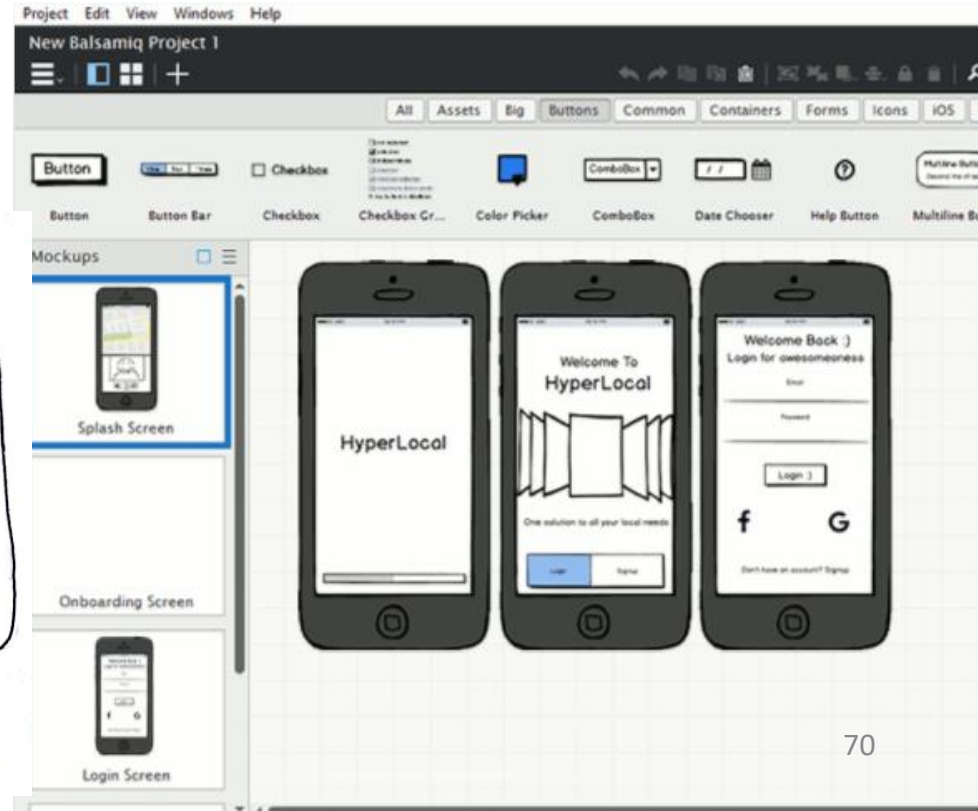

Performing a usability **test early** in the process can have **huge returns** a **paper prototype** allows to do this with a **minimal time investment**



What is Paper Prototyping? – Interaction Design Foundation

<https://www.interaction-design.org/literature/topics/paper-prototyping>

Examples of lower or higher fidelity prototypes

BRUFEN 2007 BRUFEN 400 BRUFEN 600 BRUFEN Suspensão

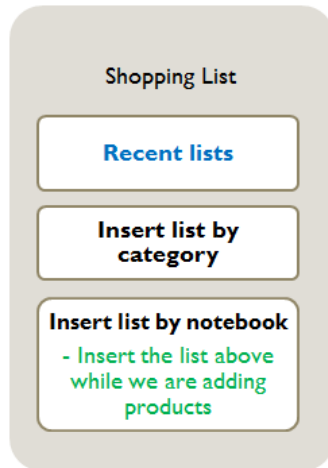
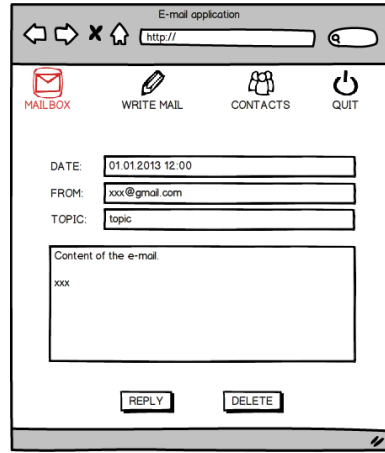
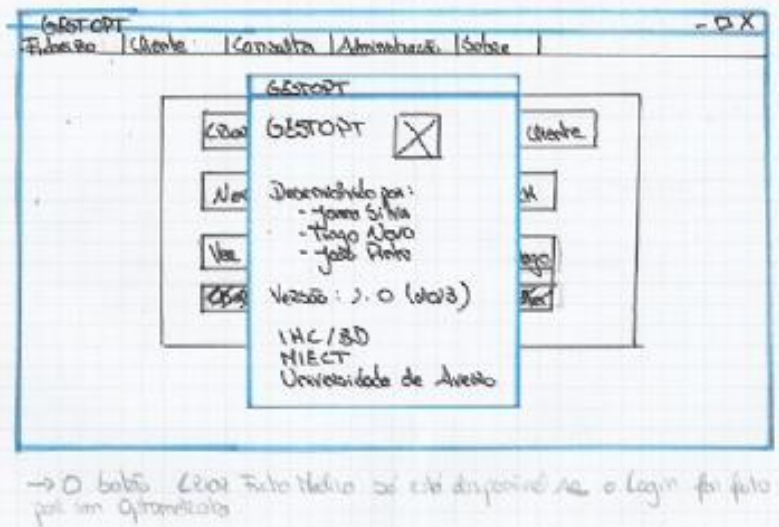
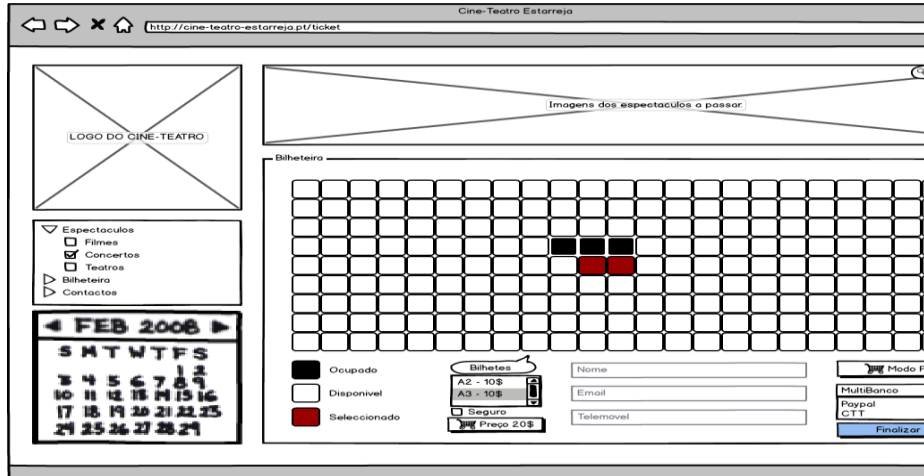

Acknowledgment

To all students who have used low fidelity prototypes in previous editions of the Human-Computer interaction course and colleagues who supervised them

Even for less conventional applications



Wizard of Oz prototyping

- A prototype that only works by having someone behind-the-scenes “pulling the levers and flipping the switches” (named after the classical film)
- A user interacts with an interface without knowing that the responses are given by someone



The “wizard” was a “man behind-the-scene”

<https://www.nngroup.com/articles/wizard-of-oz/>

https://en.wikipedia.org/wiki/Wizard_of_Oz_experiment





Example of using the Wizard of Oz method in other situations

- Definition of a set of gestures to use in a game

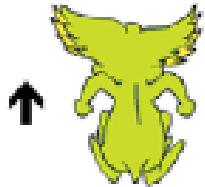

Höysniemi, J., Hämäläinen, P., Turkki, L., and Rouvi, T. 2005. "Children's intuitive gestures in vision-based action games". *Commun. ACM* 48, 1, Jan. 2005, 44-50

Example of using the Wizard of Oz method in other situations



- Haptic Wizard of Oz Prototyping aids designers in rapidly designing and testing interactive hardware like this above car cockpit

D. Leithinger, C. Zheng, and E. Y. Do, "Haptic Wizard of Oz Prototyping in VR," in *VR/MR Workshop*, 2018.

Wizard of Oz @ HCI-UA

Paulo Dias, T. Sousa, J. Parracho, I. Cardoso, A. Monteiro, Beatriz Sousa Santos
“Student Projects Involving Novel Interaction with Large Displays”, IEEE Computer Graphics and Applications, vol.34, no.2, Mar.-Apr. 2014, pp.80-86

Used to get insight on which gestures might be more intuitive to control a Pac-Man game



Main bibliography

- Cooper, A., R. Reimann, and D. Cronin, *About Face 3 The Essentials of Interaction Design*. Wiley Publishing, Inc., 2007
- The Encyclopedia of Human-Computer Interaction, 2nd Ed., Interaction Design Foundation <https://www.interaction-design.org/literature>
- Mayhew, D., *The Usability Engineering Lifecycle*, Morgan Kaufmann, 1999
- [https://books.google.pt/books/about/The Design of Everyday Things.html?id=I1o4DgAAQBAJ&printsec=frontcover&source=kp_read_button&redir_esc=y#v=onepage&q&f=false](https://books.google.pt/books/about/The_Design_of_Everyday_Things.html?id=I1o4DgAAQBAJ&printsec=frontcover&source=kp_read_button&redir_esc=y#v=onepage&q&f=false)
- Sharp, H., Y. Rogers, *Interaction Design : Beyond Human-Computer Interaction*, 5th ed., Wiley, 2019
[https://books.google.pt/books/about/Interaction Design.html?id=HreODwAAQBAJ&redir_esc=y](https://books.google.pt/books/about/Interaction_Design.html?id=HreODwAAQBAJ&redir_esc=y)
- Sommerville,, I., *Software Engineering*, 9th ed., Addison Wesley, 2010
http://ifs.host.cs.st-andrews.ac.uk/Books/SE9/WebChapters/PDF/Ch_29%20Interaction_design.pdf

Interesting Links

- <https://www.nngroup.com/>
- <http://www.usability.gov/>
- <https://uxpa.org/about-ux/>
- <https://www.usability.gov/how-to-and-tools/index.html>
- <https://www.w3.org/WAI/redesign/ucd>